



US18 SERIES - analog output - ultrasonic sensors

INSTRUCTION MANUAL

CONTROLS

Programming push-button (TEACH)

This push-button allows to program the reading points of the sensor.

PWR LED indicator	Indicates
OFF	Power is OFF.
ON Red	Target is weak or outside sensing range.
ON Green	Sensor is operating normally, good target.

OUT LED indicator	Indicates
OFF	Target is outside windows limits
ON Yellow	Target is within windows limits
ON Red (solid)	In TEACH mode, waiting for first limit
ON Red (flashing)	In TEACH mode, waiting for second limit

CONNECTIONS

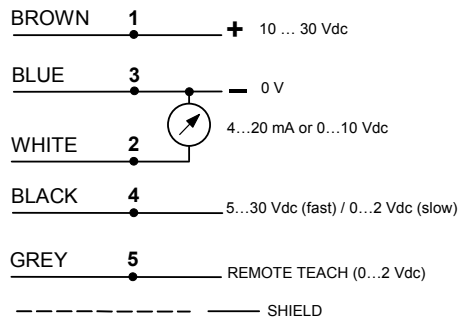

NOTE: It is recommended that the shield wire be connected to earth ground or to 0V.

PRINCIPLES OF OPERATION

Ultrasonic sensors emit one or multiple pulses of ultrasonic energy, which travel through the air at the speed of sound. A portion of this energy reflects off the target and travels back to the sensor. The sensor measures the total time required for the energy to reach the target and return to the sensor. The distance to the object is then calculated using the following formula:

$$D = \frac{ct}{2}$$

D = Distance from the sensor to the target
c = Speed of sound in air
t = Transit time for the ultrasonic pulse

To improve accuracy, an ultrasonic sensor may average the results of several pulses before outputting a new value.

Temperature Effects

The speed of sound is dependent upon the composition, pressure and temperature of the gas in which it is traveling. For most ultrasonic applications, the composition and pressure of the gas are relatively fixed, while the temperature may fluctuate.

In air, the speed of sound varies with temperature according to the following approximation:

$$C_{m/s} = 20 \sqrt{273 + T_c}$$

Cm/s = Speed of sound in meters per second
Tc = Temperature in °C

Temperature Compensation

Changes in air temperature affect the speed of sound, which in turn affects the distance reading measured by the sensor. An increase in air temperature shifts both sensing window limits closer to the sensor. Conversely, a decrease in air temperature shifts both limits farther away from the sensor. This shift is approximately 3.5% of the limit distance for a 20° C change in temperature. The US18 series ultrasonic sensors are temperature compensated. This reduces the error due to temperature by about 90%. The sensor will maintain its window limits to within 1.8% over the -20° to +60°C range.

NOTES:

- Exposure to direct sunlight can affect the sensor's ability to accurately compensate for changes in temperature.
- If the sensor is measuring across a temperature gradient, the compensation will be less effective.
- The temperature warmup drift upon power-up is less than 1.7% of the sensing distance. After 10 minutes, the apparent distance will be within 0.3% of the actual position. After 25 minutes, the sensing distance will be stable.

TECHNICAL DATA

	US18-PA AXIAL VERSION	US18-PR RADIAL VERSION
Power supply:	10 ... 30 Vdc (limit values), reverse polarity protection	
Ripple:	≤ 2 Vpp	
Consumption (load current excluded):	65mA max., 40 mA typical @ 25 Vcc	
Output configurations:	0...10 Vcc (current output) or 4...20 mA (voltage output) overload and short circuit protection	
Outputs:	Analog voltage output: 2.5 KΩ minimum load resistance. Minimum supply for a full 10V output is 12Vdc (for supply voltages between 10 and 12V, out max is at least V supply - 2) Analog current output: 1KΩ max @ 24V input. Max load resistance = (Vcc-4)/0.02 ohms For current output (4-20mA) models, ideal results are achieved when the total load resistance R = [(Vin-3)/0.020]Ω. Example, at Vin = 24V, R ≈ 1KΩ (1watt) A worst case shift of 1% of sensing distance is caused by operating the sensor at Vin = 30Vdc and R = 0Ω	
Output Response time (for a 95% step change):	2.5 ms (Fast): pin 4 (black wire) at 5...30 Vdc 30 ms (Slow): pin 4 (black wire) at 0...2 Vdc (or not connected)	
Max. switching frequency:	200 Hz (fast), 16 Hz (slow)	
Range indicator: (Red/Green)	Green Target is within sensing range Red Target is outside sensing range OFF Sensing power is OFF	
Teach/Output indicator: (Yellow/Red)	Yellow Target is within sensing range OFF Target is outside taught window limits Red Sensor is in Teach mode	
Setting:	Sensing window limits: TEACH-Mode programming of near and far window limits may be set using the push button or remotely via TEACH input	
Delay at Power-up:	300 ms	
Temperature effect:	0.02% of distance/°C	
Temperature warmup drift:	less than 1.7% of sensing distance upon power-up	
Linearity (note A):	2.5 ms response: ±1 mm 30 ms response: ±0.5 mm	
Resolution (note A):	2.5 ms response: 1 mm 30 ms response: 0.5 mm	
Minimum window size:	5 mm	
Ultrasonic emission:	300 KHz, rep. rate 2.5 ms	
Remote teach input:	Impedance: 12 KΩ	
Operating temperature:	-20 ... 60 °C	
Storage temperature:	-25 ... 70 °C	
Maximum relative humidity:	100%	
Electrical shock protection:	Class 2	
Operating distance (typical values):	30...300 mm	
Vibrations:	0.5 mm amplitude, 10...55 Hz frequency, for every axis (EN60068-2-6)	
Reference standard:	EN60947-5-2	
Shock resistance:	11 ms (30 G) 6 shock for every axis (EN60068-2-27)	
Housing material:	Thermoplastic polyester	
Threaded barrel material:	ABS/PC	
Push-button material:	Santoprene	
Light pipes material:	Acrylic	
Mechanical protection:	IP67	
Connections:	M12 - 4 pole connector	
Weight:	25 g	

DIMENSIONS

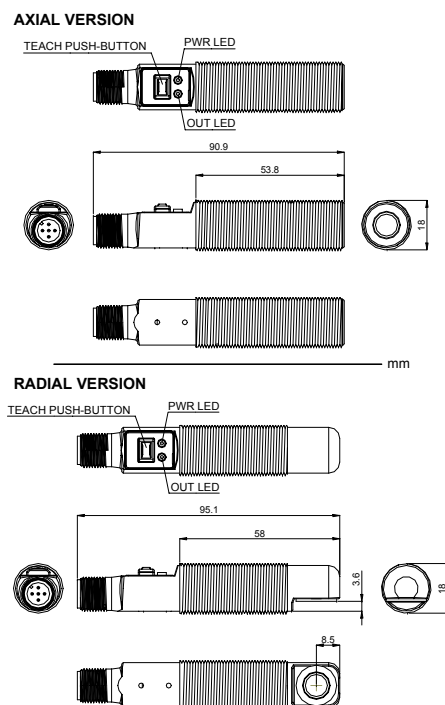

SENSOR PROGRAMMING

Two TEACH methods may be used to program the sensor:

- Teach individual minimum and maximum limits.
 - Use Auto-Window feature to center a sensing window around the taught position.
- The sensor may be programmed either via its push button, or via a remote switch. Remote programming may be used to disable the push button, preventing unauthorized personnel from adjusting the programming settings. To access this feature, connect the Remote Teach wire of the sensor to 0 - 2V dc, with a remote programming switch between the sensor and the voltage. NOTE: The impedance of the Remote Teach input is 12 KΩ.

Programming is accomplished by following the sequence of input pulses (see chap. "Normally Open/Normally Closed operation select"). The duration of each pulse (corresponding to a push button "click"), and the period between multiple pulses, are defined as "T":

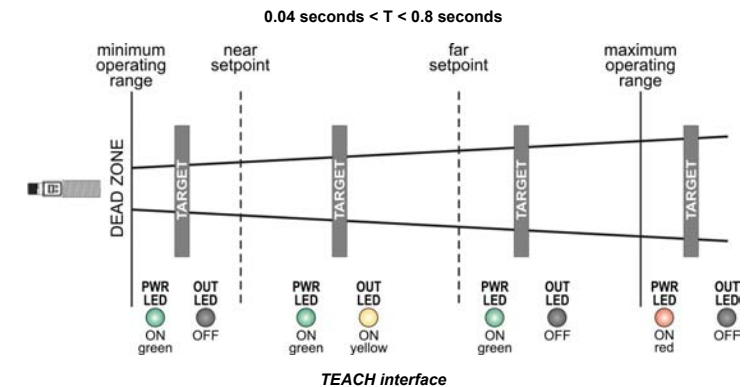

Analog Output Slope

The sensor will be programmed for either a positive or a negative output slope, based on which limit is taught first (see pictures).

- If the Near limit is taught first, the slope will be positive.
 - If the Far limit is taught first, the slope will be negative.
- The analog output signal, is automatically distributed over the width of programmed sensing window. In the event of signal loss, the analog output goes to 3.6mA or 0Vdc, which may be used to trigger an alarm.

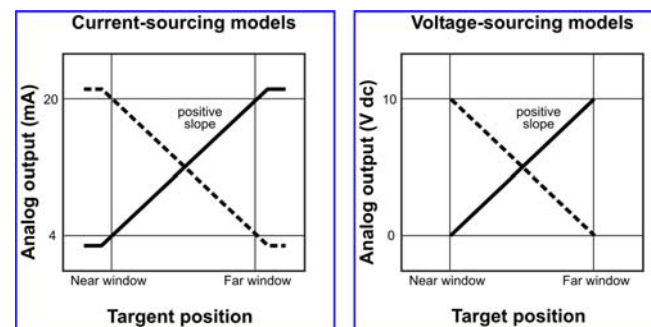

Teaching Minimum and Maximum Limits

	Programming procedure		Indicators LED
	TEACH push-button	Remote line (remote teach)	
Programming mode	Push and hold TEACH push-button	No action required; sensor is ready for 1st limit teach	OUT LED: ON, RED PWR LED: ON Green (good signal) ON Red (no signal)
TEACH First limit	Position the target for the first limit	Position the target for the first limit	PWR LED: must be ON Green
	"Click" the TEACH push-button	Single-pulse the remote line (0.04 s < T < 0.8 s)	Teach accepted: (Sensor learns the 0Vdc or 4mA limit) OUT LED, flashing Red Teach unacceptable: OUT LED, ON Red
TEACH Second limit	Position the target for the second limit	Position the target for the second limit	PWR LED: must be ON Green
	"Click" the TEACH push-button	Single-pulse the remote line (0.04 s < T < 0.8 s)	Teach accepted: (Sensor learns the 10Vdc or 20mA limit) OUT LED, Yellow or OFF Teach unacceptable: OUT LED, flashing Red

NOTE: The duration of each pulse (corresponding to a push button "click"), and the period between multiple pulses, are defined "T" (0.04 s < T < 0.8 s).

Teaching limits using the Auto-Window feature

Teaching the same limit twice for the same output automatically centers a 100mm window on the taught position (± 50 mm).

The analog output will be centered on the taught position at approximately 5V or 12mA.

	Programming procedure		Indicators LED
	TEACH push-button	Remote line (remote teach)	
Programming mode	Push and hold TEACH push-button	No action required; sensor is ready for 1st limit teach	OUT LED: ON, Red PWR LED: ON Green (good signal) ON Red (no signal)
TEACH Limit	Position the target for the center of window	Position the target for the center of window	PWR LED: must be ON Green
	"Click" the TEACH push-button	Single-pulse the remote line (0.04 s < T < 0.8 s)	Teach accepted: OUT LED, flashing, Red Teach unacceptable: OUT LED, ON Red
Re-TEACH Limit	Without moving the target, "click" the TEACH push-button again	Without moving the target, single-pulse the remote line again (0.04 s < T < 0.8 s)	Teach accepted: OUT LED, Yellow or OFF Teach unacceptable: OUT LED, flashing, Red

General Notes on Programming

The sensor will return to RUN mode if the first TEACH condition is not registered within 120 seconds. After the first limit is taught, the sensor will remain in PROGRAM mode until the TEACH sequence is finished.

To exit PROGRAM mode without saving any changes, press and hold the programming push button > 2 seconds (before teaching the second limit). The sensor will revert to the last saved program.

TEACH push-button lockout

Enables or disables the push button to prevent unauthorized personnel from adjusting the program settings.

	Programming procedure		Enable/Disable Function
	TEACH push-button	Remote line (remote teach) 0.04 s < T < 0.8 s	
TEACH Push-button lockout	Not available via push-button	Four impulse the remote line	Push-button are either enabled or disabled, depending on condition..

DECLARATION OF CONFORMITY

We DATASENSOR S.p.A. declare under our sole responsibility that these products are conform to the 89/336 CEE, 73/23 CEE Directives and successive amendments.



WARRANTY

DATASENSOR S.p.A. warrants its products to be free from defects. DATASENSOR S.p.A. will repair or replace, free of charge, any product found to be defective during the warranty period of 36 months from the manufacturing date. This warranty does not cover damage or liability deriving from the improper application of DATASENSOR products.

DATASENSOR S.p.A. Via Lavino 265
40050 Monte S. Pietro - Bologna - Italy
Tel: +39 051 6765611 Fax: +39 051 6759324
http://www.datasensor.com e-mail: info@datasensor.com

DATASENSOR S.p.A. cares for the environment: 100% recycled paper. DATASENSOR S.p.A. reserves the right to make modifications and improvements without prior notification.

826002200 Rev.00

US18 SERIES - Digital output- ultrasonic sensors

INSTRUCTION MANUAL

CONTROLS

Programming push-button (TEACH)

This push-button allows to program the reading points of the sensor.

PWR LED indicator	Indicates
OFF	Power is OFF.
ON Red	Target is weak or outside sensing range.
ON Green	Sensor is operating normally, good target.

OUT LED indicator	Indicates
OFF	Target is outside windows limits (normally open operation)
ON Yellow	Target is within windows limits (normally open operation)
ON Red (solid)	In TEACH mode, waiting for first limit
ON Red (flashing)	In TEACH mode, waiting for second limit

CONNECTIONS

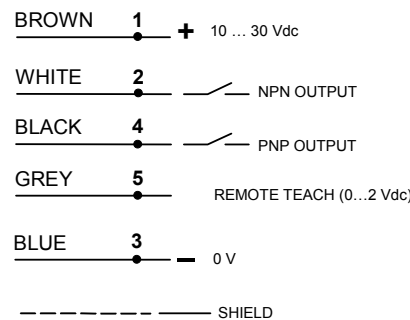

NOTE: It is recommended that the shield wire be connected to earth ground or to 0V.

PRINCIPLES OF OPERATION

Ultrasonic sensors emit one or multiple pulses of ultrasonic energy, which travel through the air at the speed of sound. A portion of this energy reflects off the target and travels back to the sensor. The sensor measures the total time required for the energy to reach the target and return to the sensor. The distance to the object is then calculated using the following formula:

$$D = \frac{ct}{2}$$

D = Distance from the sensor to the target
C = Speed of sound in air
T = Transit time for the ultrasonic pulse

To improve accuracy, an ultrasonic sensor may average the results of several pulses before outputting a new value.

Temperature Effects

The speed of sound is dependent upon the composition, pressure and temperature of the gas in which it is traveling. For most ultrasonic applications, the composition and pressure of the gas are relatively fixed, while the temperature may fluctuate.

In air, the speed of sound varies with temperature according to the following approximation:

$$C_{m/s} = 20 \sqrt{273 + T_c}$$

C_{m/s} = Speed of sound in meters per second
T_c = Temperature in °C

Temperature Compensation

Changes in air temperature affect the speed of sound, which in turn affects the distance reading measured by the sensor. An increase in air temperature shifts both sensing window limits closer to the sensor. Conversely, a decrease in air temperature shifts both limits farther away from the sensor. This shift is approximately 3.5% of the limit distance for a 20° C change in temperature. The US18 series ultrasonic sensors are temperature compensated. This reduces the error due to temperature by about 90%. The sensor will maintain its window limits to within 1.8% over the -20° to +60° C range.

NOTE:

- Exposure to direct sunlight can affect the sensor's ability to accurately compensate for changes in temperature.
- If the sensor is measuring across a temperature gradient, the compensation will be less effective.
- The temperature warmup drift upon power-up is less than 1.7% of the sensing distance. After 10 minutes, the apparent switchpoint will be within 0.3% of the actual position. After 25 minutes, the sensing position will be stable.

TECHNICAL DATA

	US18-PA AXIAL VERSION	US18-PR RADIAL VERSION
Power supply:	10 ... 30 Vdc (limit values), reverse polarity protection	
Ripple:	≤ 2 Vpp	
Consumption (load current excluded):	65mA max., 40 mA typical @ 25 Vcc	
Outputs:	NPN and PNP (N.O. or N.C. selectable)	
Output current:	100 mA max. overload and short circuit protection	
Output saturation voltage:	PNP < 1.2 V @ 10 mA, < 1.6 V @ 100 mA NPN < 200 mV @ 10 mA, < 600 mV @ 100 mA	
Response time:	5ms	
Max. switching frequency:	100 Hz	
Range indicator:	Green Target is within sensing range Red Target is outside sensing range OFF Sensing power is OFF	
Teach/Output indicator:	Yellow Target is within sensing range OFF Target is outside taught window limits Red Sensor is in Teach mode	
Setting:	Sensing window limits: TEACH-Mode programming of near and far window limits may be set using the push button or remotely via TEACH input	
Delay at Power-Up:	300 ms	
Temperature effect:	0.02% of distance/°C	
Temperature warmup drift:	Less than 1.7% of sensing distance upon power-up	
Repeatability:	0.5 mm	
Minimum window size:	5 mm	
Hysteresis:	0.7 mm	
Ultrasonic emission:	300 KHz, rep. rate 2.5 ms	
Remote teach input:	Impedance: 12 KΩ	
Operating temperature:	-20 ... 60 °C	
Storage temperature:	-25 ... 70 °C	
Maximum relative humidity:	100%	
Electrical shock protection:	Class 2	
Operating distance (typical values):	30...300 mm	
Vibrations:	0.5 mm amplitude, 10...55 Hz frequency, for every axis (EN60947-5-2)	
Reference standard:	EN60947-5-2	
Shock resistance:	11 ms (30 G) 6 shock for every axis (EN60068-2-27)	
Housing material:	Thermoplastic polyester	
Threaded barrel material:	ABS/PC	
Push-button material:	Santoprene	
Light pipes material:	Acrylic	
Mechanical protection:	IP67	
Connections:	M12 - 4 pole connector	
Weight:	25 g	

DIMENSIONS

AXIAL VERSION

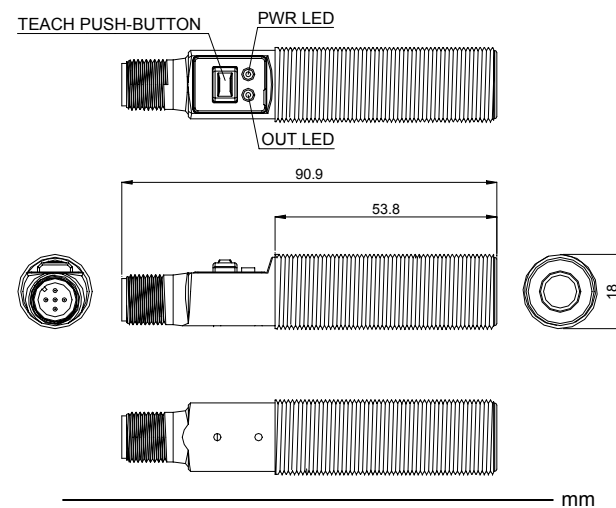

RADIAL VERSION

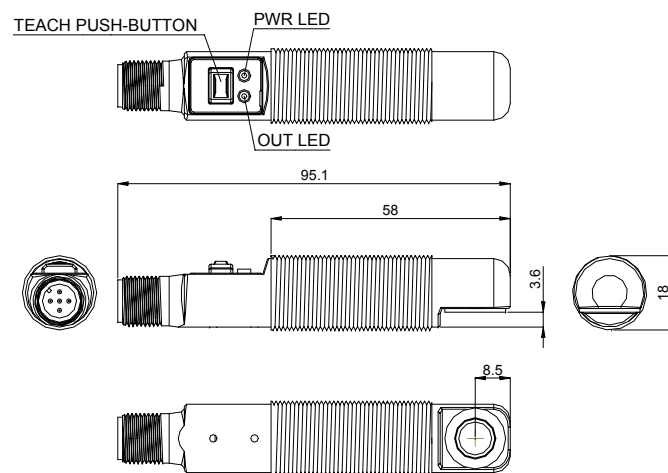

SENSOR PROGRAMMING

Two TEACH methods may be used to program the sensor:

- Teach individual minimum and maximum limits.
- Use Auto-Window feature to center a sensing window around the taught position. The sensor may be programmed either via its push button, or via a remote switch.

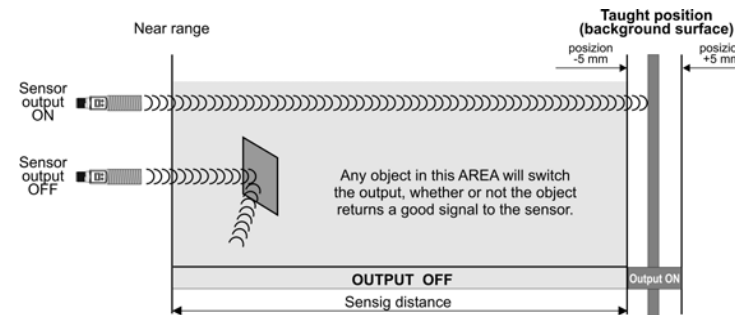

Remote programming may be used to disable the push button, preventing unauthorized personnel from adjusting the programming settings. To access this feature, connect the Remote Teach wire of the sensor to 0 - 2V dc, with a remote programming switch between the sensor and the voltage. NOTE: The impedance of the Remote Teach input is 12 KΩ.

Programming is accomplished by following the sequence of input pulses (see chap. "Normally Open/Normally Closed operation select"). The duration of each pulse (corresponding to a push button "click"), and the period between multiple pulses, are defined as "T":

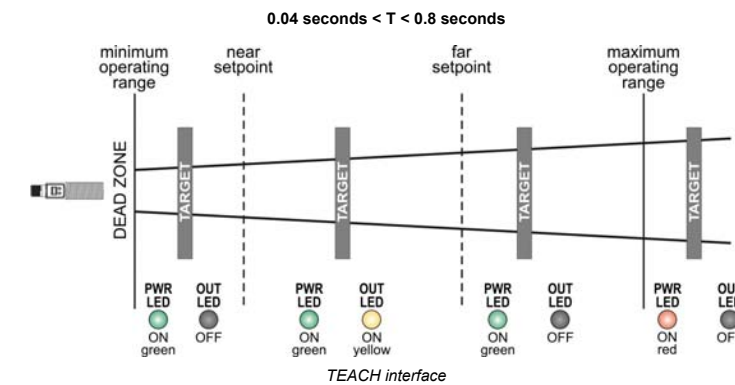

Teaching Minimum and Maximum Limits

	Programming procedure		Indicators LED
	TEACH push-button	Remote line (remote teach)	
Programming mode	Push and hold TEACH push-button	No action required; sensor is ready for 1st limit teach	OUT LED: ON, RED PWR LED: ON GREEN (good signal) ON RED (no signal)
TEACH First limit	Position the target for the first limit	Position the target for the first limit	PWR LED: must be ON GREEN
	"Click" the TEACH push-button	Single-pulse the remote line (0.04 s < T < 0.8 s)	Teach accepted: OUT LED, flashing RED Teach unacceptable: OUT LED, ON RED
TEACH Second limit	Position the target for the second limit	Position the target for the second limit	PWR LED: must be ON GREEN
	"Click" the TEACH push-button	Single-pulse the remote line (0.04 s < T < 0.8 s)	Teach accepted: OUT LED, YELLOW or OFF Teach unacceptable: OUT LED, flashing RED

NOTE: The duration of each pulse (corresponding to a push button "click"), and the period between multiple pulses, are defined "T" (0.04 s < T < 0.8 s).

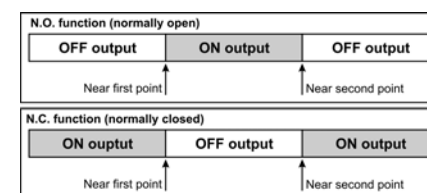

See chap. "Normally Open/Normally Closed Operation Select."

Teaching limits using the Auto-Window feature

Teaching the same limit twice for the same output automatically centers a 10 mm window on the taught position (± 5 mm).

	Programming procedure		Indicators LED
	TEACH push-button	Remote line (remote teach)	
Programming mode	Push and hold TEACH push-button	No action required; sensor is ready for 1st limit teach	OUT LED: ON, RED PWR LED: ON GREEN (good signal) ON RED (no signal)
TEACH Limit	Position the target for the center of window	Position the target for the center of window	PWR LED: must be ON GREEN
	"Click" the TEACH push-button	Single-pulse the remote line (0.04 s < T < 0.8 s)	Teach accepted: OUT LED, flashing, RED Teach unacceptable: OUT LED, ON RED
Re-TEACH Limit	Without moving the target, "click" the TEACH push-button again	Without moving the target, single-pulse the remote line again (0.04 s < T < 0.8 s)	Teach accepted: OUT LED, YELLOW or OFF Teach unacceptable: OUT LED, flashing, RED

TAUGHT POSITION

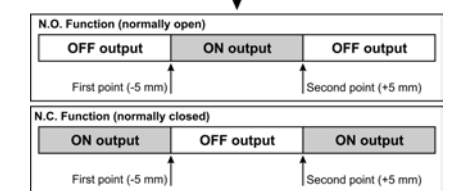

See chap. "Normally Open/Normally Closed Operation Select."

General Notes on Programming

The sensor will return to RUN mode if the first TEACH condition is not registered within 120 seconds. After the first limit is taught, the sensor will remain in PROGRAM mode until the TEACH sequence is finished. To exit PROGRAM mode without saving any changes, press and hold the programming push button > 2 seconds (before teaching the second limit). The sensor will revert to the last saved program.

Normally Open/Normally Closed Operation Select

The sensor can be configured for either normally open or normally closed via the remote teach wire (gray). A series of three pulses on the line will toggle between normally open and normally closed operation. Normally open is defined as the output energizing when the target is present. Normally closed is defined as the output energizing when the target is absent.

	Programming procedure		N.O./N.C. function
	TEACH push-button	Remote line (remote teach) 0.04 s < T < 0.8 s	
Toggle between N.O./N.C. operation	Not available via push-button	Triple-pulse the remote line	Either normally open or normally closed operation is selected, depending on previous condition.

TEACH push-button lockout

Enables or disables the push button to prevent unauthorized personnel from adjusting the program settings.

	Programming procedure		Enable/Disable Function
	TEACH push-button	Remote line (remote teach) 0.04 s < T < 0.8 s	
TEACH Push-button lockout	Not available via push-button	Four impulse the remote line	Push-button are either enabled or disabled, depending on condition..

DECLARATION OF CONFORMITY

We DATASENSOR S.p.A. declare under our sole responsibility that these products are conform to the 89/336 CEE, 73/23 CEE Directives and successive amendments.

WARRANTY

DATASENSOR S.p.A. warrants its products to be free from defects. DATASENSOR S.p.A. will repair or replace, free of charge, any product found to be defective during the warranty period of 36 months from the manufacturing date. This warranty does not cover damage or liability deriving from the improper application of DATASENSOR products.

DATASENSOR S.p.A. Via Lavino 265
40050 Monte S. Pietro - Bologna - Italy
Tel: +39 051 6765611 Fax: +39 051 6759324
http://www.datasensor.com e-mail: info@datasensor.com

DATASENSOR S.p.A. cares for the environment: 100% recycled paper. DATASENSOR S.p.A. reserves the right to make modifications and improvements without prior notification.