



POWERWARE® 9120

User's Guide

6000VA

POWERWARE®

www.powerware.com

POWERWARE 9120

6000VA

User Guide

Important Notice

The UPS ground (earth) conductor carries leakage current from the loads in addition to any leakage current generated by the UPS. This UPS generates no more than 1 mA of current. To limit the total leakage current to 3.5 mA, the load leakage must be limited to 2.5 mA. The UPS must have a good (low-impedance) ground (protective earth) connection to provide a safe path for leakage current.

If You Have a Question

Customer Support

If you have a question or problem, Table 10, Troubleshooting, may help. If you need more help, **please have your UPS model number and serial number (on the back label) nearby, and call the Invensys office nearest you (see the Invensys offices section).** Invensys' service technicians have in-depth knowledge of the UPS and power problems.

Invensys may tell you the UPS must be returned. If this happens, we will give you a Return Authorisation (RA) number. **When you return a Powerware 9120 to the factory for any reason, please use the original packing material in which your unit was shipped to you. You may be responsible for repair charges for damaged units which are not packed in Powerware packing material.** If you have discarded the original packing material, please call the nearest Invensys office so that we can ship new packing material to you. If you have any questions, please feel free to call or fax the nearest Invensys office. Please do not return your Powerware 9120 without calling Invensys first. Invensys will advise you where to ship your Powerware 9120.

Invensys reserves the right to change specifications without prior notice.

Table of Contents

	Safety Instructions	2
1.0	UPS Features	3
2.0	Installation	4
	2.1 Environment	4
	2.2 Rear Panel View	5
	2.3 Connections to Mains and Load	6
3.0	Quick Startup	9
4.0	Operation	10
	4.1 UPS Front Panel	10
	4.2 Turning the UPS On	11
	4.3 Turning the UPS Off	11
	4.4 Standby Mode	11
	4.5 Diagnostic Tests	11
5.0	Configuration	12
6.0	Additional UPS Features	15
	6.1 Inverter Shutdown	15
	6.2 Communication Port	15
	6.3 Communication Slot	16
	6.4 SNMP/Web Adaptor	16
	6.5 Relay Card	17
7.0	Installing Lansafe Software	17
8.0	Replacing the Batteries	18
	8.1 How to Replace Internal Batteries	19
	8.2 Recycling the Used Battery	20
9.0	Specifications	21
10.0	Troubleshooting	23
11.0	Warranty	27
	Invensys Australia/New Zealand Offices	31

Trademarks

Windows is a registered trademark of Microsoft Corporation.

All other brand and product names are trademarks or registered trademarks of their respective holders.

Safety Instructions

IMPORTANT SAFETY INSTRUCTIONS! SAVE THESE INSTRUCTIONS!

This User Guide contains important instructions for your Powerware 9120 that must be followed during installation and maintenance of the UPS and batteries.



CAUTION!

Whenever the Powerware 9120 is “On,” there may be dangerous voltage present at the unit’s outlet terminals. This is because the unit’s battery supplies power even if the unit is not connected to supply. The unit contains dangerous voltages.

To reduce the risk of electric shock, install in a temperature-controlled and humidity-controlled indoor area free of conductive contaminants.

With the exception of the user-replaceable batteries, all servicing of this equipment must be performed by qualified service personnel.

Before maintenance or repair, all connections must be removed. Before maintenance, repair, or shipment, the unit must be completely switched off and unplugged or disconnected.

The installation and use of this product must comply with all national, federal, state, municipal, or local codes that apply. For assistance, call Invensys Service or your local Invensys office.

If the Powerware 9120 has been damaged during shipment, call your vendor immediately.

If the Powerware 9120 is stored, the batteries should be recharged every 6 months. If stored above 25° Celsius, recharge the batteries more often.

1.0 UPS Features

The Powerware 9120 provides protection against power problems, including power outages, brownouts, and sudden increases in power. It also provides spike suppression and line noise filtering to protect your equipment. Front panel LEDs and an audible alarm keep you aware of the unit's status. Use the drawings on this and the following pages to identify features of the unit.

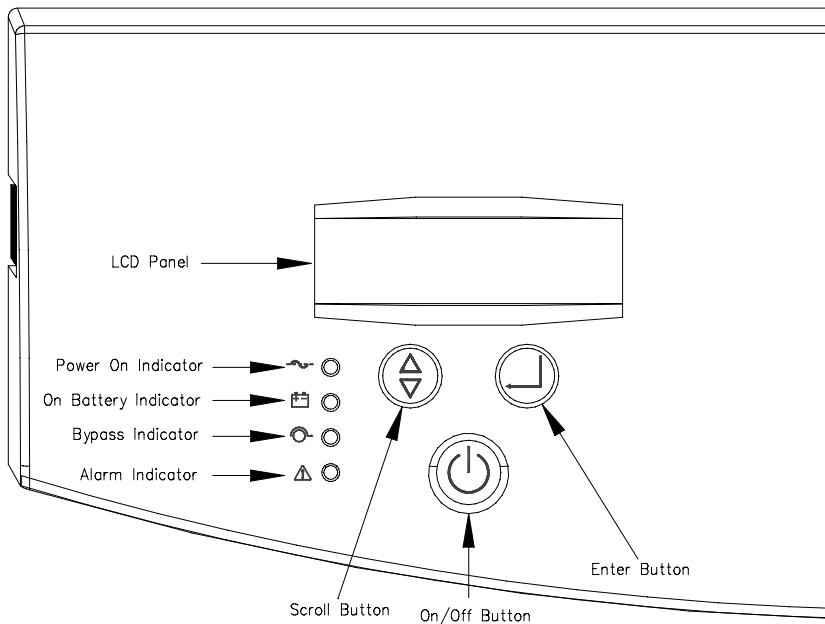

Fig 1. Powerware 9120 6kVA Controls and Indicators

2.0 Installation

2.1 Environment

1. The UPS should be installed in a controlled environment. A controlled environment is one that is indoor, temperature controlled, free from conductive contaminants, dust, fumes and moisture.

The UPS is intended for indoor use only.

Provide adequate ventilation, 100 mm clearance at the rear of the UPS and 50 mm on the sides of the UPS.

The unit must have unrestricted airflow.

To maximise the battery life, an ambient temperature of 15°C to 25°C is recommended.

2. Environmental Specifications

Ambient Operating Temperature	< 1500m	0°C to 40°C
	1500m - 3000m	10°C to 35°C
Recommended Temperature		15°C to 25°C
Storage Temperature		-15°C to +50°C
Cooling Type		Forced Air
Humidity		0.95% non-condensing

2.2 Rear Panel View

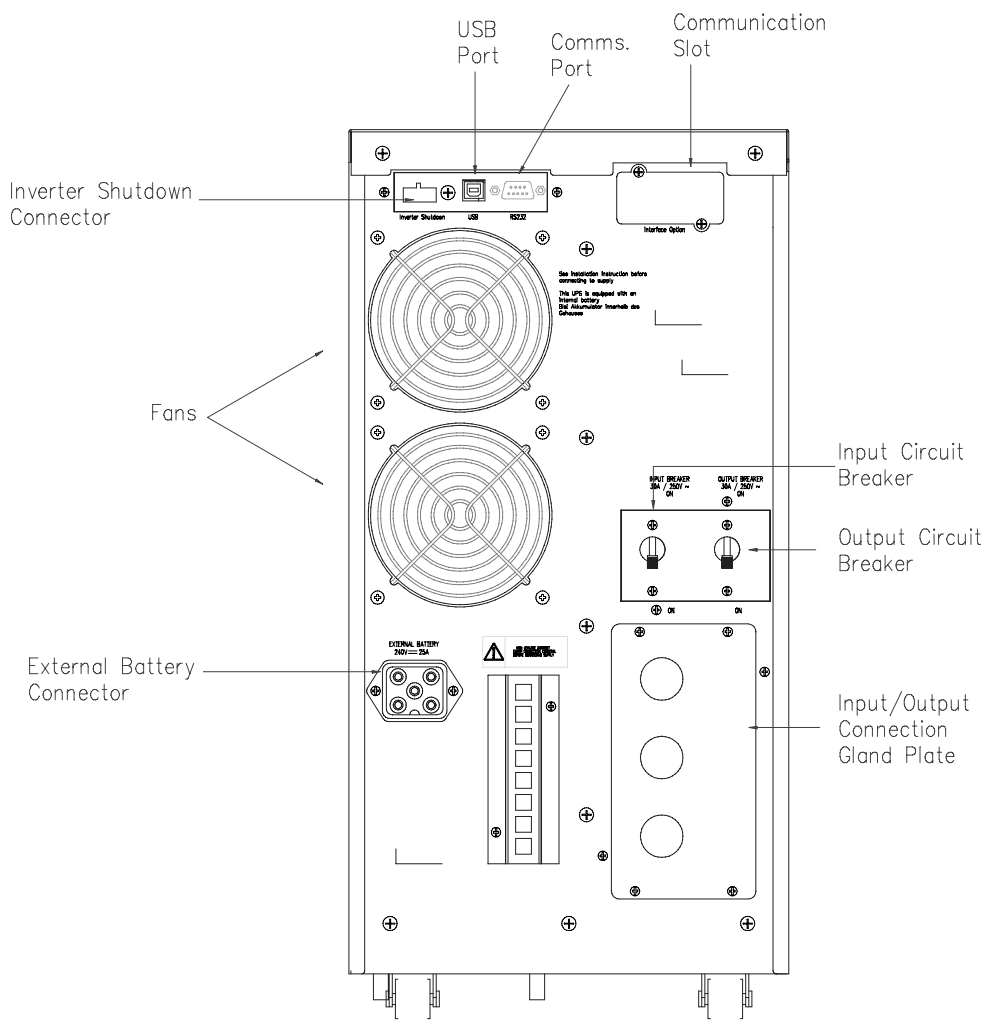

Fig 2. Powerware 9120 6kVA Rear Panel

2.3 Connections to Mains and Load

The installation, wiring and connection must be carried out by qualified personnel only. The installation must comply with all current Wiring Rules and Regulations, Local, State and Federal statutes, Legislation and Regulations.



CAUTION !

The UPS contains high voltage and current levels which could injure or kill personnel and damage equipment.

2.3.1 Installing the UPS

1. Ensure that the UPS protective device and the cabling are sized to accommodate the ratings as listed in Figs 3 & 4.
2. Install UPS wiring system in accordance with Fig 5, for a Single Supply Input, or Fig 6 for a Dual Supply Input. A Dual Supply is normally to provide additional system validating in the event of a feeder failing.

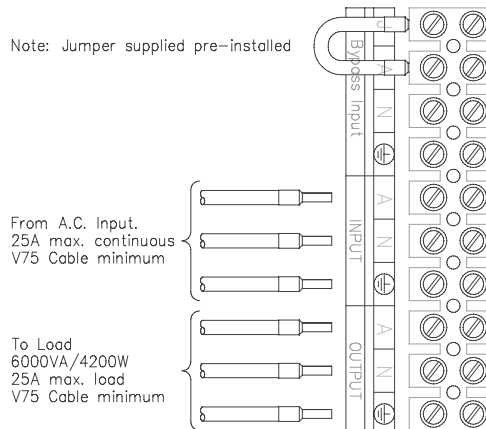

Fig 3. Single Supply Wiring

- Note:**
1. Max Cable Size into Terminals is 10sq. mm. Stranded Cable
 2. For Wiring Diagram refer to Fig 5

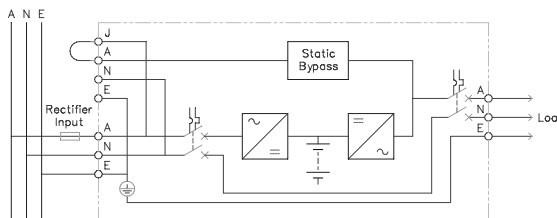

Fig 5. Single Supply Wiring

Note: For Terminal Connection refer to Fig 3

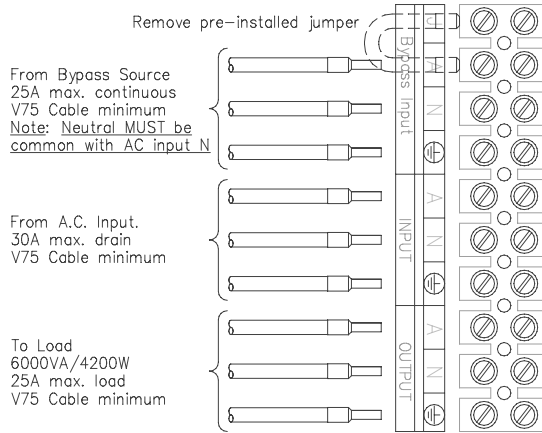

Fig 4. AC Supply with Separate Bypass Supply

- Note:**
1. Max Cable Size into Terminals is 10sq. mm. Stranded Cable
 2. Currents quoted are for 240V AC units
 3. For Wiring Diagram refer to Fig 6

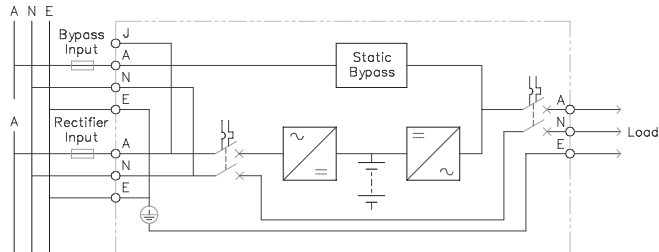

Fig 6. AC Supply with Separate Bypass Supply

Note: For Terminal Connection refer to Fig 4

2.3.1 Installing the UPS (cont.)

3. Isolate the Supply service and secure against reclosing. The Input and Output Circuit Breakers located at the rear of the UPS must be in the "OFF" position.
4. Connect to the UPS in accordance with Fig 3 for a Single Supply Input or Fig 4 for a Dual Supply Input.
NOTE: When connecting a Dual Supply Input (i.e. AC Supply with a Separate Bypass Supply), the pre-installed Jumper between J and A (on the Bypass Input Terminals) **MUST BE REMOVED**.
5. The Inverter Shutdown Input is located at the rear of the UPS. When this connection is open, the Inverter of the UPS will be shutdown. We strongly recommend the use of an External Maintenance Bypass Switch (MBS). If an MBS is used, connect the inverter shutdown cable (refer Fig 2 Page 5) to the input at the rear of the unit, utilising a 1sq. mm. twisted pair screened cable.
6. If computer or alarm connections are required, they should be connected in accordance with the relevant portion of Section 6 of this manual or in accordance with the manual provided with the option. These connections are on the rear panel.

2.3.2 Installing External Battery Cabinets

1. External Battery Cabinets should only be connected when the UPS is isolated from the mains and the load.
2. Connect the External Battery Cabinet to the UPS with the battery cable provided. If more than one External Battery Cabinet is installed, connect the second Battery Cabinet to the first Battery Cabinet with the cable provided.

NOTE: If External Battery Cabinets are used, the Battery Pack Quantity and type in the UPS Parameters should be changed. Do this once the UPS has been started (refer to Section 5.0, Configuration and to the manual that came with your External Battery Pack).

3.0 Quick Startup

- 1 Your Powerware 9120 6kVA UPS is designed for direct connection to a mains supply by a qualified electrician. When input power is connected and switched on the LCD backlight will illuminate and the fan will run, but no output power is available.
- 2 Let the unit charge the battery for at least 3 hours. You may use the unit while the battery charges, but the battery backup runtime will be reduced until the battery is fully charged.
- 3 Start the Powerware 9120 by pressing and holding the On/Standby button (large button in the center of the front panel) in for about one second. Note: To turn the unit on, the On/Standby button must be pressed for about one second and for about 5 seconds to turn the unit off.
 - 3.a. When it starts, the unit beeps once, then twice, and lights the “Power On” LED. The unit indicates “On Delay” on the LCD and performs an internal system and battery test. Next, the Powerware 9120 applies AC output to the output connections and indicates “On Line” on the LCD.
 - 3.b. After 10 seconds or less, the self test is complete. The green LED will come on and remain on. If the unit beeps, or if the green LED does not remain on even though input power is available from the input supply, go to the Troubleshooting section.
- 4 Switch off the equipment you want to protect, and plug each load into outlets connected to the circuits feeding the Powerware 9120.
- 5 Switch on the protected equipment, one load at a time. If the UPS beeps an alarm when you start your equipment, the UPS may be overloaded. See the Troubleshooting section.

The LCD on the front of the UPS shows the % of load capacity that your equipment is using. See Section 3.0 Operation for more information on checking the load %..
- 6 Please fill out the warranty registration card in Section 10 and return it to your local Invensys office.

4.0 Operation

This section describes:

- The UPS front panel
- Turning the UPS on and off
- Starting the UPS on battery
- Standby mode
- Diagnostic tests

4.1 UPS Front Panel

The UPS front panel indicates the UPS status and also identifies potential power problems. Figure 7 shows the UPS front panel indicators and controls.

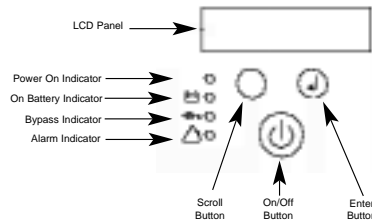







Figure 7. UPS Front Panel

NOTE If the alarm beeps or if the  indicator is on, see Table 8 in Section 10.0 to identify and correct the problem. To configure parameters through the front panel, see Section 5.0 "Configuration".

Display Mode

To view the UPS current settings, press the  button for one second and release. Use the  button to scroll through the list of settings, which appear in the following order:

LCD Message	Description
I/P VOLT= xxx.xV	Input voltage.
Bypass V= xxx.xV	Bypass voltage
Bypass F= xx.xHZ	Bypass frequency
O/P VOLT= xxx.xV	Output voltage.
O/P FREQ= xx.xHZ	Output frequency.
O/P Load = x%	Approximate percentage of UPS load capacity being used by the protected equipment.
O/P Watt= xW	Output watts.
O/P VA= xVA	Output VA.
O/P Cur= x.xA	Output current.
BAT VOLT= xx.xV	Battery voltage.
BAT CHARGE= xxx%	Approximate percentage of battery capacity remaining.
BackUp Time= xxxM	Approximate battery time remaining in minutes. The display changes to seconds after one minute (Backup Time= xxxS).
CPU Version x.xx	Firmware revision level.

NOTE The UPS exits Display mode automatically after five seconds if the  button is not pressed. Pressing the  button for 3 seconds will lock the display at the present parameter. Pressing again for 3 seconds releases the meter.



4.2 Turning the UPS On

After the UPS is connected to a power source, the fan turns on and the UPS enters Standby mode. To turn on the UPS, press and hold the  button until you hear the UPS beep (approximately one second). The LCD briefly displays "On Delay" and the "Power On" indicator illuminates. Then the UPS conducts a self-test, briefly displaying "On BATTERY". If an alarm condition occurs, see Table 8 in Section 10.0 for helpful hints.

When the self-test is complete, the LCD displays "On Line" indicating that power is available from the UPS output receptacles.

Starting the UPS on Battery

NOTE Before using this feature, the UPS must have been powered by utility power at least once and the batteries must be completely charged.

To turn on the UPS without using utility power, press and hold the  button until you hear the UPS beep (approximately one second). The UPS supplies power to your equipment and goes into Battery mode. The LCD briefly displays "On Delay", then "On Battery" and the  and  indicators illuminate. When the UPS starts on battery, it does not conduct a self-test to conserve battery power.

4.3 Turning the UPS Off

To turn off the UPS, press and hold the  button until the long beep ceases (approximately five seconds).

NOTE When you press and hold the  button, the LCD displays **Shutdown Pending**.

The  indicator turns off and the LCD briefly displays UPS OFF before going blank. The fan continues to run and the UPS remains in Standby mode until you unplug or remove utility power from the UPS.

4.4 Standby Mode

When the UPS is turned off and connected to a power source, the UPS is in Standby mode. The fan continues to run and the battery recharges when necessary. The  indicator is off and the LCD panel is blank, indicating that power is not available from the UPS.

4.5 Diagnostic Tests

The UPS automatically performs a self-test when powered on and when the UPS restarts after a power outage. The self-test monitors the UPS electronics and battery and indicates any problems on the front panel.



A battery test is automatically performed every 30 days (720 hours) of continuous Normal mode operation. The test lasts approximately 15 seconds and any failure is displayed on the front panel. Both the UPS and battery tests can be performed manually (see Section 5.0 "Configuration" for more information).

5.0 Configuration



This section describes how to reconfigure options using the Configuration mode, including: input and output voltage and frequency, site wiring fault, and silencing the alarm.

NOTE *The UPS has been factory-configured with default settings appropriate for most installations. User configuration is not normally required.*



Configuration Mode

The control buttons ( and ) are used to modify the UPS configuration. Figure 8 shows the front panel and Table 1 explains the corresponding options.

NOTE The UPS can be configured while in Battery mode. If the UPS switches to battery power while in Configuration mode, the UPS exits Configuration mode and indicates Battery mode on the front panel.

1. Press the  button for one second to enter Configuration mode.
The LCD displays the first configuration parameter (see Table 1).
2. Press the  button to scroll through the parameters.

NOTE *The UPS exits Configuration mode automatically after five seconds if a selection has not been made.*

3. Press the  button to select the parameter.
4. Press the  button to scroll through the options for the selected parameter; press the  button to select the option.

You may be prompted to save the selection; press the  button to save. Other options are saved automatically. See Table 1 for more detail.

5. To exit Configuration mode at any time, do not press any buttons for five seconds.
The UPS returns to Normal mode and displays On Line.

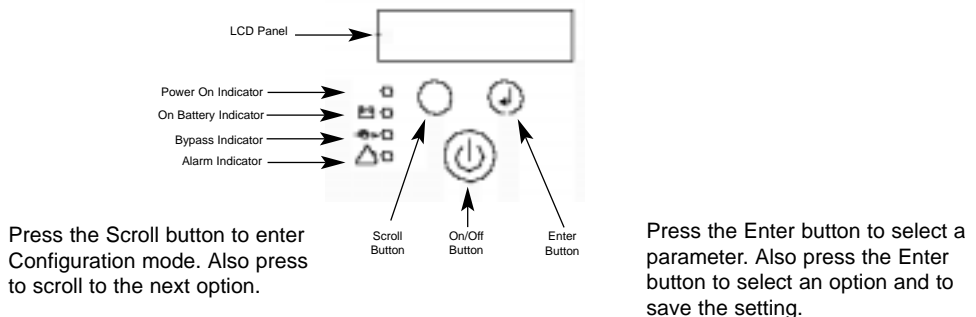

Figure 8. Using the Configuration Mode

Table 1. Configuration Mode Parameters

Parameter	LCD Message	Description	Default Settings
Output Voltage Setting	O/P V Setting	To change the output voltage • Select 208, 220, 230, or 240V for 240V models. You are prompted to save this setting.	For 240V models: O/P V= 240V
Input Voltage Tolerance	Bypass Volt Set	Select the input voltage tolerance range before the UPS goes to Battery mode: $\pm 10\%$, $+10\%/ -15\%$, or $+15\%/ -20\%$. You are prompted to save this setting.	I/P Tol= $\pm 10\%/ -15\%$
Input Frequency	Bypass Freq Set	The factory-default is 50 or 60 Hz, $\pm 5\%$. Select $\pm 2\%$ for a narrower frequency range. Select $\pm 7\%$ for a wider frequency range. You are prompted to save this setting.	Freq Tol= $\pm 5\%$
High-Efficiency Mode	HE Mode Setting	Select whether High-Efficiency mode is On or Off. If enabled, you must also select the input voltage range: $\pm 10\%$ or $\pm 15\%$. While operating in High-Efficiency mode, the UPS transfers to inverter when: 1) the input voltage is outside $\pm 10\%$ or $\pm 15\%$ from nominal; 2) the input frequency is greater than $\pm 3\%$; or 3) the input line is not available. You are prompted to save this setting. If the setting is not allowed, the LCD shows "I/P out limit" which means the input voltage or frequency is not suitable	HE Mode Off
Free Run Mode	Free Run Mode	Select whether Free Run mode is On or Off. If enabled, you must also select Bypass Disable or Bypass Enable. This selection defines how your UPS runs when the input frequency (from the utility) is outside the selected frequency tolerance (set via the I/P F Setting, above), but is inside the maximum frequency limits the UPS can accept before switching to Battery mode. For example: If your 50 Hz UPS is set to the factory default window of $\pm 5\%$ before the UPS starts regulating the frequency. • The output frequency tracks the input frequency exactly from 47.5 to 52.5 Hz. • If input frequency is between 45 and 65 Hz, the output frequency is regulated by the UPS to exactly 50 Hz (± 0.5 Hz). You are prompted to save this setting.	Free Run On (Bypass Disable)
Alarm Silence	Alarm Silence	Select whether Silence is On or Off. If enabled, the UPS silences the alarm for an existing fault. If the UPS status changes, the alarm beeps, overriding the previous alarm silencing. The alarm does not silence if there is a low battery condition.	Silence Off

Table 1. Configuration Mode Parameters (cont.)

Parameter	LCD Message	Description	Default Settings
Manual Battery Test	Manual BAT Test	To initiate a manual battery test, press the \downarrow button twice when "Manual Battery Test" is displayed on the LCD. During the test the LCD displays ON BATTERY. The UPS resets the automatic timer after a manual battery test. The LCD displays "Battery not charged" when UPS test is requested but the battery is not fully charged.	Battery Test
Manual UPS Test	Manual UPS Test	To initiate a manual UPS self-test, press the \downarrow button twice. During the test, the LCD displays ON BATTERY.	UPS Test
Site Wiring Fault Alarm	Site Fault Set	Select Enable or Disable. When enabled, the alarm sounds when the ground connection is missing or the line and neutral wires are reversed in the wall outlet.	Detect Enable
Modem Support	Modem Support?	This parameter is reserved for future use, and should not be modified by the user.	No Modem Support
Number of Extended Battery Modules	Select EBM Type	Select the number of EBMs connected to the UPS: Select 0 through 5. You are prompted to save this setting. Refer to the documentation that came with your battery pack for more information.	Extern Pack: 0
Communications Lock-out	COM Control Cmds	For greater levels of security, users may choose to have the UPS disregard shutdown commands that come from the power management software or other communication sources. <ul style="list-style-type: none"> • When disabled, the UPS does not accept a shut down command via the communication port, USB port, or communication slot adapter. • When enabled, the UPS operates normally in response to external commands. You are prompted to save this setting.	Enable
Load Segment Control	Load Group Set	Allows manual control of load segments (see "Load Segments" Section 5.3) By repeatedly pressing the scroll button, the individual load segments can be turned on and off. CAUTION To prevent the unintentional shutdown of specific load segments, confirm your selection before pressing the \downarrow button.	Group 1On 2On
NOTE: Not applicable to 6kVA units			
Manual Bypass	Manual Bypass GO	This parameter is used to manually place the UPS in Bypass mode.	Bypass OFF
Configuration Mode Setting	Config Mode Set	This parameter is reserved for future use, and should not be modified by the user. The setting may be toggled between EscapeConfigMode and Enter ConfigMode. It should always be set to EscapeConfigMode.	EscapeConfigMode

6.0 Additional UPS Features

This section describes:

- Inverter Shutdown
- Network Transient Protector
- Load segments
- Using the communication port or USB port
- Optional Powerware communication cards

6.1 Inverter Shutdown

The Powerware 9120 includes a port that allows the UPS inverter to be switched off.

This feature is designed to be used with Powerware External Maintenance Bypass Switches. Refer to the instructions provided with the switch for further information.



WARNING

The Inverter Shutdown circuit is an IEC 60950 safety extra low voltage (SELV) circuit. This circuit must be separated from any hazardous voltage circuits by reinforced insulation.

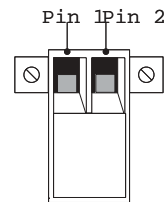

Figure 9. Inverter Shutdown Connector

6.2 Communication Port (standard)

To establish communication between the UPS and a computer, connect your computer to the UPS communication port using the supplied communication cable.

When the communication cable is installed, power management software can exchange data with the UPS. The software polls the UPS for detailed information on the status of the power environment. If a power emergency occurs, the software initiates the saving of all data and an orderly shutdown of the equipment.

The pin functions are described in Table 2.

Table 2. Communication Port Pin Assignment

Pin Number	Signal Name	Function	Direction from the Multi-Port Module
1	Low Batt	Low Battery signal	Out
2	RxD	Transmit to external device	Out
3	TxD	Receive from external device	In
	RS-232 low level signal for >0.4 seconds	Conditional Power Off: In absence of AC power, output is turned off after 120 seconds until normal AC power returns	In
4	DTR	Signal from external device	In
5	GND	Signal Ground	-
6	-	Tied to Pin 4	-
7	-	No Connection	-
8	AC Fail	AC Fail signal	Out
9	Power Source	+V (8 to 24 volts DC power)	Out

USB Port

The UPS is also equipped with a USB communication port. Either the DB-9 communication port or the USB port may be used to monitor the UPS; however, they cannot operate simultaneously. Refer to the power management software instructions for using the USB port.

6.3 Communication Slot

The Powerware 9120 UPS has a communication slot that allows quick installation of the optional SNMP/Web adapter or future communication interfaces. These interface adapters extend the capabilities of the Powerware 9120 system to provide compatibility with network and remote monitoring/management systems.

6.4 SNMP/Web Adapter

This adapter provides the Powerware 9120 system with its own ethernet network connection, allowing it to be remotely monitored and controlled via industry-standard internet browsers. The HTML interface enables UPS monitoring and management from anywhere on the internet or within your intranet. In addition, third-party Simple Network Management Protocol (SNMP) software packages may also be used to communicate remotely with the Powerware 9120 system.

6.5 Relay Card (optional extra)

This interface provides true relay contact output to peripheral devices. Outputs are user-selectable as normally open or normally closed.

Table 3. Relay Card (AS/400) Pin Assignment

Pin Number	Signal Name	Definition	Direction
1	-	Isolated common to pins 2 & 3	-
2	Line OK	Relay contact; closed to pin 1	-
3	Line Failure	Relay contact; closed to pin 1	-
4	-	Isolated common to pins 5 & 6	-
5	Battery Normal	Relay contact; closed to pin 4	-
6	Battery Low	Relay contact; closed to pin 4	-
7	-	Isolated common to pins 8 & 9	-
8	UPS Alarm	Relay contact; closed to pin 7	-
9	UPS On/OK	Relay contact; closed to pin 7	-
10	-	Isolated common to pins 11 & 12	-
11	UPS Online/Inverter	Relay contact; closed to pin 10	-
12	UPS on Bypass	Relay contact; closed to pin 10	-
13	+12VDC	Signal supply +12VDC	Out
14	Signal GND	Signal ground - Common	-
15	UPS Shutdown	Minimum 5 seconds high level signal (+12VDC) to perform shutdown according to following Relay Card Jumper settings:	In

	JP1 (default)	JP2	JP3
UPS Normal	-	No response	Go to bypass mode, back online when shutdown pins opened
UPS on Battery	Output off after 120 sec. Back online on resumption of AC power	Immediate output off UPS shutdown in 12 seconds	Immediate output off UPS shutdown in 12 seconds

7.0 Installing Software Suite

Your UPS is supplied with a CD-ROM and communication cable to install and operate Software Suite. To install Software Suite on your computer, follow the instructions enclosed with the Software Suite CD-ROM.

8.0 Replacing the Batteries

The Powerware 9120 batteries are user-replaceable and can be replaced while the Powerware 9120 has AC input applied and powers the loads. This means that, if necessary, you can replace the batteries while the UPS is running. Before you replace the batteries, make sure that you read the safety information below.

Note: If you have a power outage while you are replacing the batteries, the UPS will not be able to run on battery power and your protected equipment will shut down.



CAUTION!

The batteries used in the UPS and battery pack can produce dangerous voltage and high current. Therefore, the batteries may cause severe injury if their terminals contact a tool or the UPS cabinet. Be very careful to avoid electrical shock and burns from contacting terminals while you replace the batteries.

Batteries contain caustic acids and toxic materials and can rupture or leak if mistreated. Remove rings and metal wristwatches or other jewelry. Do not carry metal objects in your pockets: these objects could fall into the UPS.

Never allow any tool to contact both a battery terminal and the UPS cabinet or another battery terminal. Do not lay tools or metal parts on top of batteries.

To ensure continued superior performance of your UPS and to maintain proper charger operation, you must replace the UPS batteries with the same number and type of batteries. These batteries must be the same type as the original batteries: valve-regulated, low maintenance. The replacement batteries should have the same voltage and ampere-hour rating as the original batteries.

Assume that old batteries are fully charged. Use the same precautions you would use when handling a new battery. Do not short battery terminals with a cable or tool! Batteries contain lead. Many areas have regulations about disposing of used batteries. Please dispose of old batteries properly. DO NOT dispose of batteries in a fire because the batteries could explode. Do not open or mutilate batteries. Released electrolyte is harmful to the skin and eyes. It may be toxic.

This equipment may produce ozone. Take precautions to ensure that the concentration of ozone is limited to a safe value (0.1 ppm {0.2 mg / m} calculated as an 8-hour time-weighted average).

8.1 How to Replace Internal Batteries

Use the following steps to replace the internal batteries:

1. Remove screws where indicated (a).
2. Using caution not to put stress on the LCD display cable, pull the top panel forward and place it on top of the UPS.

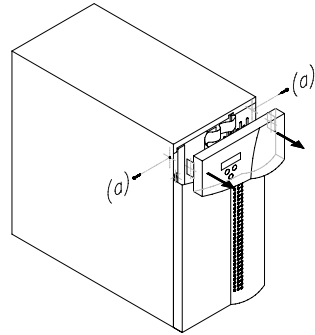

3. Unscrew the bottom panel screws (b).
4. Lift up the front panel to disengage the locking tabs and then pull the panel forward to remove.

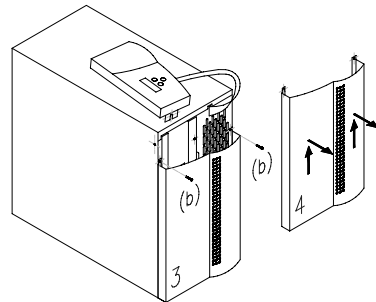

5. Remove Battery Cover "A" screws where indicated. Rotate cover in direction of arrow and remove cover.
6. Remove Battery Cover "B" screws where indicated. Slide cover to the right then lift to remove.

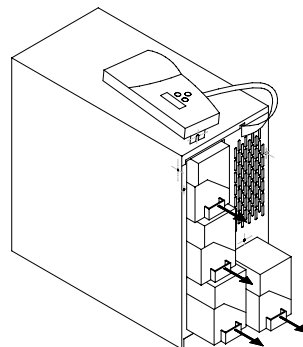

7. Pull the upper batteries out and place onto a flat, stable surface.
8. Pull the lower batteries out and place onto a flat, stable surface.
9. Remove the batteries from their cradles. See “Recycling the Used Battery” for proper disposal.
10. Install the new batteries.
11. Reinstall the trays and battery covers.
12. Reinstall the lower, then upper front covers.

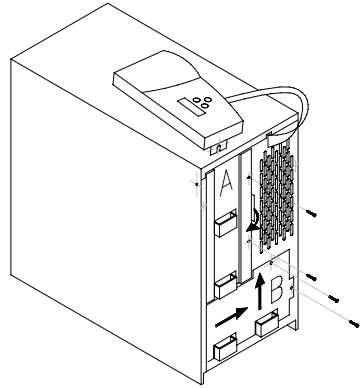

8.2 Recycling the Used Battery

Contact your local recycling or hazardous waste centre for information on proper disposal of the used battery.



WARNING

- Do not dispose of the battery or batteries in a fire. Batteries may explode. Proper disposal of batteries is required. Refer to the local codes for disposal requirements.
- Do not open or mutilate the battery or batteries. Released electrolyte is harmful to the skin and eyes. It may be toxic.



CAUTION

Do not discard the UPS or the UPS batteries in the trash. This product contains sealed lead-acid batteries and must be disposed of properly. For more information, contact your local recycling or hazardous waste centre.

9.0 Specifications

Invensys reserves the right to change specifications without prior notice.

This section provides the following specifications for the Powerware 9120 6kVA model:

- Electrical input and output
- Environmental and safety
- Weights and dimensions
- Battery

Table 4. Electrical Input

	240V Models
Nominal Voltage	240V default; 208, 220, 230, 240V selectable
Voltage Range	184-276V for 208, 220, 230, 240V nominal Low line is 120V at 25% load, 140V at 50% load, 160V at 75% load, 184V at 100% load without battery discharge
Nominal Frequency	50/60 Hz, $\pm 5\%$ user-selectable
Noise Filtering	MOVs and line filter for normal and common mode noise
Connections	Hardwired Input 10mm ² max. cable, separate bypass source, terminals standard
Input Power Factor	0.97
Max. Input Current	30A

Table 5. Electrical Output

	240V Models
Power Levels (rated at nominal inputs)	6000VA, 4200W
Regulation (Normal mode)	Nominal output voltage $\pm 2\%$
Overload Capacity	100 - 125% 1 minute 125 - 150% 10 seconds
Voltage Waveform	Normal mode: Sine wave; <5% THD with full PFC and nonlinear load
Output Connections	Hardwired 10mm ² cable maximum

Table 6. Environmental and Safety

240V Models	
Operating Temperature	0°C to 40°C 0-1500 metres above sea level 0°C to 35°C 1500-3000 metres above sea level Optimal battery performance: 25°C
Storage Temperature	-15°C to 50°C
Relative Humidity	0-95% noncondensing
Operating Altitude	Up to 3,000 metres above sea level
Audible Noise	Less than 55 dBA
Surge Suppression	ANSI/IEEE C62.41 (1991); ANSI/IEEE C62.45 (1987) Category B
Safety Conformance	AS/NZS 3260
EMC	AS/NZS 2064, AS/NZS 3548, C-Tick Marked, AS/NZS 61000-4-2, -3, -4, -5 Compliant, AS/NZS 62040-2

Table 7. Weights and Dimensions

UPS 240V Models	
Dimensions (WxDxH)	280 x 580 x 570 mm
Weight	91kg

Table 8. Battery

240V Models	
Battery Rating	7Ah, 12V
Battery Quantity	20
Backup Time (full load)	8 minutes
Recharge Time	Less than 8 hours for 90%
Battery Type	Sealed lead acid, maintenance free

10.0 Troubleshooting

If you have a question or problem, the troubleshooting table may help (See Table 8). If you need assistance, phone Invensys Service or your local Invensys office. Please have the model number and serial number (located on the rear of the unit) available.

If the unit must be returned, Invensys will give you a Return Authorisation (RA) number. Phone Invensys National Service & Repair Centre on 1300 303 059 for an RA number before returning the unit for any reason.

This section explains:



- UPS alarms and conditions
- How to silence an alarm

Audible Alarms and UPS Conditions

The UPS has an audible alarm feature to alert you of potential power problems. When the alarm is activated, the UPS beeps in different intervals according to a particular condition. Use Table 10 to determine and resolve the UPS alarms and conditions.

Silencing an Audible Alarm

There are two ways to silence the alarm for an existing fault:

- Press one of the front panel control buttons ( ,  , or ).
- Turn the Alarm Silence option on through the front panel (see Section 5.0 "Configuration").

If UPS status changes, the alarm beeps, overriding the previous alarm silencing. The alarm does not silence if there is a low battery condition.

Table 8. Troubleshooting

LCD Message or Condition	Possible Cause	Action
UPS does not turn on.	The UPS is not correctly connected to the power source.	Check connections to the power source.
	The wall outlet is faulty.	Have a qualified electrician test and repair the outlet.
	The Inverter Shutdown connector is missing or open.	Reconnect or close the Inverter Shutdown switch (see Section 6.1) Restart the UPS.
	A circuit breaker or an input fuse on the rear panel is open.	Push the circuit breaker button or replace the fuse. Restart the UPS.
LCD panel is blank.	The UPS is in Standby mode.	Press and hold the  button until you hear the UPS beep (approximately one second)
	The LCD has failed.	Contact your service representative.
UPS does not provide the expected backup time	The battery may be fully discharged because of: <ul style="list-style-type: none"> • long-term storage • frequent power outages • end of battery life 	Connect the UPS to a power source for 24 hours to charge the battery. Perform a battery test (see Section 4.0 "Configuration") If the battery test fails, see Section 8.0 "Replacing Batteries" to replace the battery. During extended power outages, save your work and turn off your equipment to conserve battery power.
The UPS operates normally, but some or	The equipment is not connected to the UPS.	Verify that the equipment is properly connected to the UPS.
all of the protected equipment is not on.	The output circuit breaker (if applicable) is open.	Reset the circuit breaker (push the circuit breaker button or reset the switch).
On-Battery 1 beep every 5 seconds.	Utility power failure.	The UPS is powering your equipment with its internal battery. If this is an extended power outage, save your work and turn off your equipment to conserve battery power.

Table 8. Troubleshooting (cont.)

LCD Message or Condition	Possible Cause	Action
Low Battery 2 beeps every 5 seconds.	The battery is running low.	2 minutes or less of battery power remains (depending on load and battery charge). Prepare for a shutdown. Save your work and turn off your equipment. The alarm cannot be silenced.
BAT Test Failure 3 beeps every 5 seconds.	The battery needs replacing.	See Section 8.0 "Replacing Batteries" to replace the battery.
O/P Overload 2 beeps per second.	Power requirements exceed UPS capacity (110-125% for 1 minute or 126-150% for 10 seconds) or the load is defective. The UPS switches to Bypass mode.	Remove some of the equipment from the UPS. The UPS automatically switches back to Normal mode when the capacity returns to an acceptable level. You may need to obtain a larger capacity UPS.
BAT O/P Overload 2 beeps per second.	The UPS is on battery, and the power requirements exceed UPS capacity (130% for 10 seconds or >130% for 1.5 seconds) or the load is defective.	Shutdown is imminent (30 seconds). Save your work and turn off your equipment. Turn off and unplug or remove utility power from the UPS. Remove some of the equipment from the UPS. Restart the UPS. You may need to obtain a larger capacity UPS.
Site Fault 1 beep per second.	Ground wire connection does not exist or the line and neutral wires are reversed in the wall outlet.	Have a qualified electrician correct the wiring. To disable this alarm, see Section 5.0 "Configuration"
Battery Test	The UPS is performing a battery test.	None. The UPS returns to Normal mode when it completes a successful battery test.
Over Temperature Constant beep.	UPS internal temperature is too high.	Shutdown is imminent. Save your work and turn off your equipment. Turn off the UPS. Clear vents and remove any heat sources. Ensure the airflow around the UPS is not restricted. Wait at least 5 minutes and restart the UPS. If the condition persists, contact your service representative.

Table 8. Troubleshooting (cont.)

LCD Message or Condition	Possible Cause	Action
Overcharge Constant beep.	Batteries are over-charged.	Save your work and turn off your equipment. Turn off the UPS. Contact your service representative.
O/P Short Constant beep.	Output short circuit.	Save your work and turn off your equipment Turn off the UPS. Contact your service representative.
High O/P V Constant beep.	High output voltage.	Save your work and turn off your equipment. Turn off the UPS. Contact your service representative.
Low O/P V Constant beep.	Low output voltage.	Save your work and turn off your equipment. Turn off the UPS. Contact your service representative.
DC Bus Fault 2 beeps per second.	High internal DC bus voltage.	Save your work and turn off your equipment. Turn off the UPS. Contact your service representative.
Bypass not Avail	Bypass voltage outside bypass range.	Warning only. Adjust bypas input voltage, if possible

11.0 Warranty

WARRANTY Information

This Warranty is subject to Invensys Energy Systems Pty Ltd (IES) standard Conditions of Sale which govern all sales of products by Invensys Energy Systems Pty Ltd.

1. IES products, in general, are warranted against failure due to faulty materials and/or workmanship for a period of two years from despatch date (ex IES store) as per invoice. The Ferroresonant and 95 Series Power Conditioners and Dry Type Transformers have an extended warranty - 5 years from date of despatch.
2. If, within the applicable Warranty period, any IES product does not meet the warranty specified above, and the product was installed and operated in accordance with Australian standards and IES standard installation procedures, IES shall thereupon correct any defects due to faulty materials and/or workmanship.
3. Any modifications made to the product other than those made by IES or its authorised representative may cause the Warranty to be void.
4. For units up to 3kVA that are installed as a portable device, the Warranty covers repair or replacement of defective parts at the factory, or other service locations as nominated by IES, provided the unit has been returned by the user packed adequately to prevent shipping damage, and approval has been obtained from IES before shipment. All costs associated with the return of the product to IES are at the customer's expense.

For hardwired products 3kVA and above, the Warranty covers on site repair (Metropolitan area, Capital Cities only) during normal working hours, by IES technicians or appointed agents. For units installed in remote locations, IES may, at its discretion, request the equipment to be recovered and returned to the factory or other nominated service locations. In this case, it is the customer's responsibility to pack the equipment adequately to prevent shipping damages and pay freight charges to the location nominated by IES. Approval to return goods must be obtained from IES before the goods are despatched.

5. Units returned for in-warranty repairs, which are found not to be defective, will be subject to an inspection and handling charge, plus transportation charges.
6. High grade batteries, designated for Uninterruptible Power Supply (UPS) applications, are supplied by IES for use with IES UPS equipment. These batteries have a finite life expectancy depending on a number of variables, including rate of discharge, depth of discharge, operating temperature, etc.

7. Providing that the batteries are used within the limits as set out in the battery manufacturer's warranty statement and are provided as an integral part of new equipment, they are guaranteed for two years, from despatch date as per invoice. A copy of this warranty statement is available on request. Batteries provided as spare parts or replacements have a one year warranty. Other optional warranty terms for batteries are available on request.
8. IES reserves the right to charge for replacement batteries if within the one year guarantee period replacement batteries are necessary as a result of misuse or misapplication by the purchaser or end user.

AFFIX
POSTAGE
STAMP

Invensys Energy Systems Pty Ltd
13 Healey Road
DANDENONG VIC 3175
AUSTRALIA

Standard Warranty Registration



UPS Model Number: UPS Serial Number: Date of Purchase:/...../.....

Contact Person:

Company/Organisation:

Address:

City: State: Country: Postcode:

Telephone: Fax: E-mail:

1. Where did you purchase this Powerware UPS from?

- Retail Store Computer Store Invensys Distributor Direct from Invensys
 Electrical Wholesaler Mail Order Catalogue Internet Other

2. Why did you purchase a Powerware UPS? (Check all that apply)

- Recommendation Reputation After Purchase Support Features
 Price Other

3. What price did you pay for this Powerware UPS?

4. What features of a UPS are important to you?

- Appearance Front Panel Display Backup Time RS232
Communications UPS Management Software Other

5. What equipment do you intend to protect with this Powerware UPS?

- Personal Computer(s) Workstation(s) Service/Network Equip.
 Midrange Computer(s) Mainframe(s) Industrial Automation
 Telecommunications Equipment Retail/Point-of-Sale Equipment Facilities/
Building wide protection Other

6. Please specify the equipment being protected by your Powerware UPS?

Brand.....Model Operating System

7. How would you classify your type of business?

- Retail Wholesale/Distribution Manufacturing Telecommunications
 Government/Education Banking/Finance Restaurant/Hotel Other

8. What is your company's annual revenue?

- Less than \$1m \$1m-\$5m \$5m-\$20m \$20m-\$100m Greater than \$100m

9. Approximately how many personal computers are there in your company?

- Less than 10 10-20 20-50 50-200 Greater than 200

10. Do you plan to purchase more UPS or Power Protection products?

- Within 1 month 1-6 months 6-12 months Unlikely

11. Would you like information about Invensys Extended Warranty ?

- Yes No

12. Would you like to be kept informed about new Invensys product developments and be added to our customer service database?

- Yes (you will receive mail from Invensys at least three (3) times per year) No

Invensys Australia/New Zealand Offices

Head Office - Sydney

Invensys Energy Systems Pty Ltd ABN 82 054 056 709

119-127 Wicks Road

North Ryde NSW 2113

Phone: 61-2-9878 5000

Fax: 61-2-9887 2186

National Service and Repair Centre 1300 303 059

Web Site: www.powerware.com

Customer Service Offices

Adelaide

PO Box 481, Marlestone Business Centre

SA 5033

Phone: 08-8347-3622

Fax: 08-8445-6328

Brisbane

Unit 4, 11 Donkin Street

West End QLD 4101

Phone: 07-3891-1211

Fax: 07-3891-2492

Melbourne

13 Healey Road

Dandenong VIC 3175

Phone: 03-9706-5022

Fax: 03-9794-9150

Perth

23 Geddes Street

Balcatta WA 6021

Phone: 08-9240-5655

Fax: 08-9240-5644

Sydney

119-127 Wicks Road

North Ryde NSW 2113

Phone: 02-9949-6000

Fax: 02-9907-9802

Auckland

14 The Boulevard, Sunnyhills-
Pakuranga

Auckland New Zealand 1706

Phone: 09-576-6842

Fax: 09-576-6843

You have purchased a UPS that will provide you with many years of service, protecting your equipment from surges, sags, and blackouts. This product incorporates the highest quality standards in engineering, manufacturing and testing, and carries a 2 year warranty against defects in material and workmanship. This product is backed by over 60 years of pride and integrity. We are sure you will agree, there is no substitute for a Powerware product.

Did you know that Invensys also makes:

- Single Phase UPS systems up to 15kVA
- Three Phase UPS systems to 120kVA
- Parallel Three Phase UPS Systems to 1MVA
- Plug in Power Conditioners to 3kVA
- Hardwired Single Phase Power Conditioners to 22.5kVA
- Constant Voltage Transformers to 7.5kVA
- AC/DC switching and linear Power Supplies
- CVDC Constant Voltage Ferroresonant Power Supplies
- Low Voltage General Purpose Transformers
- Industrial Control Transformers
- Telecommunications DC Systems

Invensys products are available through an extensive distribution network. These distributors offer literature, technical assistance, and a wide array of off-the-shelf products for the fastest possible delivery. In addition, Invensys field sales offices are conveniently located to provide prompt attention to customer needs. Call Invensys direct to find the location of your closest authorised distributor.

Invensys: Worldwide Manufacturers of Power Protection, Conversion and Transformation Products