

Liebert® PSI™

User Manual—750/1000/1500/2200/3000, 230VAC



TABLE OF CONTENTS

IMPORTANT SAFETY INSTRUCTIONS	1
GLOSSARY OF SYMBOLS	3
1.0 INTRODUCTION	4
2.0 WHAT'S INCLUDED	5
3.0 INSTALLATION	6
3.1 Preparation	6
3.2 Tower UPS Installation	7
3.3 Rack-Mount UPS Conversion and Installation	8
3.4 Orient Display for Installation	9
3.5 Connect Input Power and Load	9
3.6 Connect Network Surge protection	10
3.7 Connect Communication Interface	10
3.8 Set Up Liebert MultiLink software	11
3.9 EPO Switch	11
4.0 CONTROLS AND INDICATORS	12
4.1 Control Buttons	13
4.1.1 On/Alarm Silence/Manual Self-Diagnostic Test	13
4.1.2 Off Button	13
4.2 Status Indicators	13
4.2.1 Status Change Button	13
4.2.2 Load Level Indicator	13
4.2.3 Battery Level Indicator	14
4.2.4 UPS Status Indicators	14
5.0 OPERATIONAL MODES	15
5.1 Normal Mode	15
5.2 Buck/Boost Mode	15
5.3 Battery Mode	15
5.4 Battery Recharge Operation	15
6.0 COMMUNICATION	16
6.1 DB-9 Connector	16
6.2 Remote Shutdown Via the DB-9 Connector	16
6.2.1 Any Mode Shutdown Via Pins 5 & 6	16
6.2.2 Battery Mode Shutdown Via Pins 4 & 5	16
6.3 RJ-45 Data Line Protection Connectors	16
6.4 UPS Communications	17
6.5 UPS Inverter/Transfer Voltage Configurations	17

7.0	BATTERY MAINTENANCE	18
7.1	Battery Charging, Storage	18
7.2	Internal Battery Replacement Procedure	18
8.0	SPECIFICATIONS	19
9.0	TROUBLESHOOTING	21

FIGURES

Figure 1	Front view of UPS	4
Figure 2	750, 1000 and 1500—rear view	4
Figure 3	2200 and 3000—rear view	4
Figure 4	Accessories	5
Figure 5	Placing the Liebert PSI	6
Figure 6	Tower configuration—attach Tower Stand	7
Figure 7	Convert the Liebert PSI for rack installation	8
Figure 8	Orienting the UPS display	9
Figure 9	Connect mains power and load	9
Figure 10	Connect network surge protection	10
Figure 11	Connect communication interface	10
Figure 12	EPO connection for normally open operation	11
Figure 13	Display and status indicators	12
Figure 14	DIP switch settings for 230V system	17
Figure 15	Battery replacement	18

TABLES

Table 1	Display and status indicators function, legend	12
Table 2	Status indicators—color, illumination mode	14
Table 3	DB-9 pin assignment	16
Table 4	Voltage configurations	17
Table 5	Liebert PSI specifications	19
Table 6	Load Autonomy - Liebert PSI 750VA-3000VA	20
Table 7	Troubleshooting—problems, causes and solutions	21

IMPORTANT SAFETY INSTRUCTIONS

SAVE THESE INSTRUCTIONS

This manual contains important instructions that should be followed during installation and maintenance of the UPS.

- Intended for installation in a temperature-controlled, indoor area free of conductive contaminants.
- Maximum ambient temperature 40°C (104°F).

Read this manual thoroughly before attempting to install or operate this UPS.

The equipment can be installed and operated by individuals without previous training.

Size of Branch Circuit Overcurrent Protection



CAUTION

To reduce the risk of fire, connect PS3000RT3-230 models only to a circuit provided with 30 amperes maximum branch circuit overcurrent protection in accordance with IEC60950-1, VDE0805, EN62040-1-1. Other Liebert PSI models must be connected to a circuit with 20 amperes maximum branch circuit overcurrent protection.



WARNING

Install the UPS indoors in a temperature- and humidity-controlled room, free of conductive contaminants, moisture, flammable liquids, gases and corrosive substances.

Some components are live, even when AC power is disconnected. For service, contact a properly trained and qualified technician. Do not remove the cover; the UPS has no user-serviceable parts inside except the internal battery pack.

Operate the UPS only from a properly grounded (earthed) 220-240 VAC, 50Hz or 60Hz AC supply.



WARNING

Although the UPS has been designed and manufactured to ensure personal safety, improper use can result in electrical shock or fire. To ensure safety, observe the following rules:

- Turn Off and unplug the UPS before cleaning it. Clean the UPS with a dry cloth. Do not use liquid or aerosol cleaners.
- Do not install or operate the UPS in or near water.
- Never block or insert any objects into the ventilation holes or other openings of the UPS. Keep all vents free of dust accumulation that could restrict air flow.
- Do not place UPS power cord anywhere it might be damaged.

Battery Handling Precautions



WARNING

Batteries should be replaced only by properly trained and qualified personnel knowledgeable of batteries and required precautions.

A battery can present a risk of electrical shock and high short-circuit current. The following precautions must be observed when working on batteries:

- Remove watches, rings and other metal objects.
- Use tools with insulated handles.
- Do not dispose battery or batteries in a fire. The battery may explode.
- Do not open or mutilate the battery or batteries. Released electrolyte is toxic. It may cause injury to the skin and eyes.
- When replacing the battery, use the type of battery as is listed in **Table 5**.
- Handle, transport and recycle batteries in accordance with local regulations.

CONDITIONS OF USE—The mains supply socket must be within 1.8m (6ft.) of the UPS and be easily accessed.

This UPS provides conditioned power to connected equipment. It is designed for commercial use only. It is not intended for use with life-support and other designated “critical” devices. Maximum load must not exceed that shown on the UPS rating label. If uncertain, consult your local dealer, local Emerson Network Power representative or Channel Support Applications.

The Liebert PSI™ 750, 1000 and 1500 models are not supplied with an input power cable for connection to the mains supply socket. Use the input mains supply power cable from your data processing equipment to connect the UPS to the mains supply.

For the Liebert PSI 2200 and 3000 models, use the supplied 16A-rated input mains supply cables. For UK supply systems, consult a properly trained and qualified electrician to connect the lead supplied for the 2200 and 3000 models to the mains supply.

The UPS and connected load total earth leakage current must not exceed 3.5mA. If the connected load earth leakage current is likely to exceed 2.5mA or if you are unsure, then convert the input cable attachment to either a fixed wiring installation or an industrial plug/socket (e.g., CEE 17 connector).

This alteration should be carried out by a properly trained and qualified electrical engineer who is conversant with local electrical codes and regulations.

When installing the UPS or making input and output connections, comply with all relevant safety codes and standards (e.g. IEC60950-1, VDE0805, EN62040-1-1).

The batteries inside the UPS use components that are dangerous for the environment, such as electronic cards and other electronic components. Any component that is removed must be taken to specialized collection and disposal centers. If this unit must be dismantled, this must be done by specialized personnel who are properly trained and qualified. The unit must be taken to a center specialized in collection and disposal of dangerous substances.

Placing magnetic storage media on top of the UPS may result in data corruption.

ELECTROMAGNETIC COMPATIBILITY—The Liebert PSI series complies with the requirements of EMC Directive 89/336/EEC and the published technical standards. Continued compliance requires installation in accordance with these instructions and use of Emerson Network Power-approved accessories only.

When using the communication features on this UPS, ensure the cabling connected to the DB-9 or UPS communications ports are kept separated from the power leads to the UPS input and output.

NOTICE

Do not connect equipment that could overload the UPS or demand half-wave rectification from the UPS, for example: electric drills, vacuum cleaners, laserjet/inkjet printers, hair dryers, overhead projectors.

Battery service should be performed or supervised by personnel knowledgeable about batteries and required precautions.

When replacing batteries, replace with the same type and number of batteries or battery packs.



CAUTION

Do not dispose of batteries in a fire. The batteries may explode.



CAUTION

Do not open or mutilate batteries. Released electrolyte is harmful to the skin and eyes. It may be toxic.

GLOSSARY OF SYMBOLS



Risk of electrical shock



Indicates caution followed by important instructions

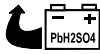

Indicates the unit contains a valve-regulated, lead-acid battery



Recycle



DC voltage



Equipment grounding conductor



Bonded to ground



AC voltage



ON/Alarm Silence/Manual Self-Diagnostic Test



OFF



Status Change Button

1.0 INTRODUCTION

The Liebert PSI is a 2U, line-interactive UPS that may be installed in a rack or used as a tower UPS. Status indicators on the front of the Liebert PSI display load level, battery level, buck/boost, site-wiring fault, overload, battery status and UPS operation. Controls include a combination On/Alarm Silence/Manual Self-Diagnostic Test button, an Off button and a Status Change button.

The Liebert PSI has USB, DB-9 (contact closure) and Liebert IntelliSlot® ports. The DB-9 and USB ports provide detailed operating information including voltages, currents, and alarm status to the host system when used in conjunction with Liebert MultiLink™ software.

The Liebert PSI is compliant with the Restriction of Hazardous Substances Directive (ROHS), prohibiting use of six hazardous materials manufacturing of electronics, including lead-free solder.

Figure 1 Front view of UPS

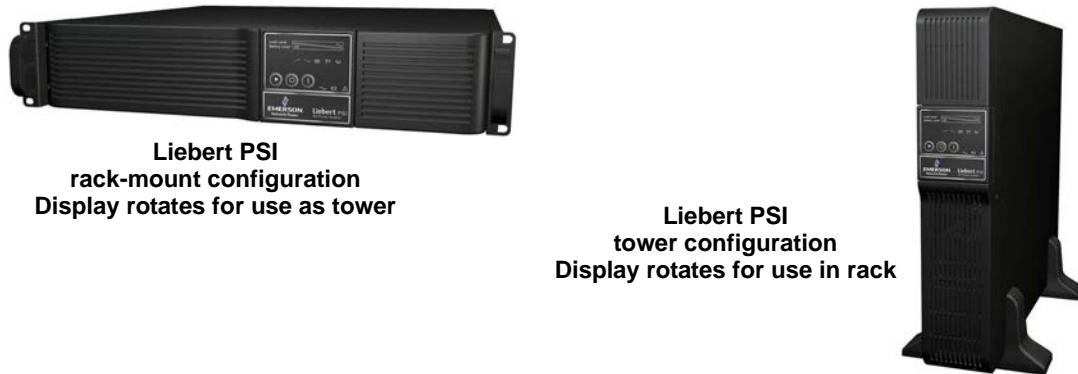

Figure 2 750, 1000 and 1500—rear view

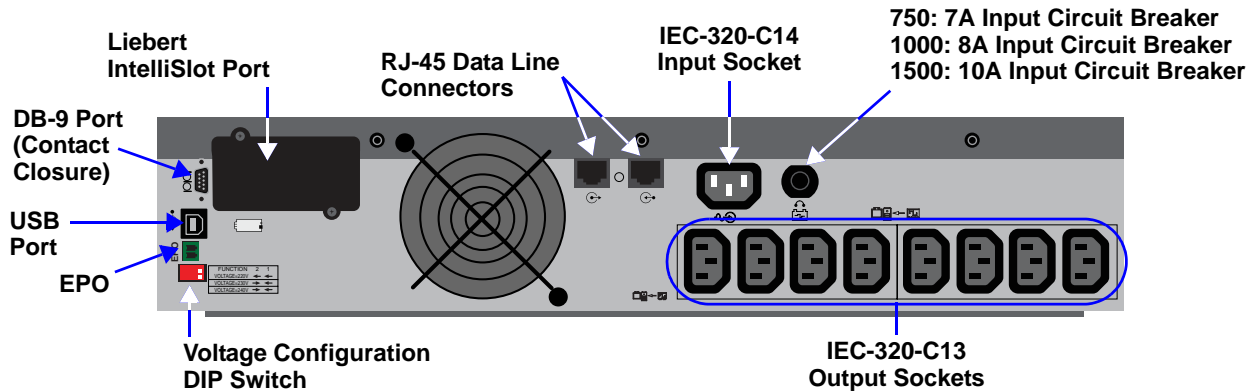
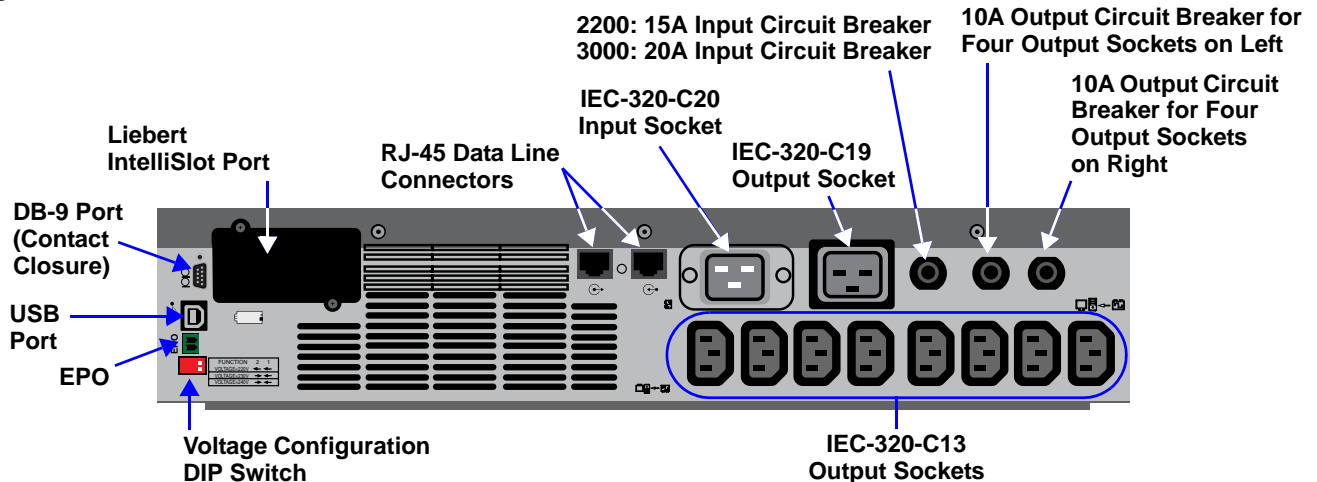

Figure 3 2200 and 3000—rear view



2.0 WHAT'S INCLUDED

The Liebert PSI is shipped with the following items:

- Multi-Language User Manual on CD
- Liebert MultiLink Software and User Manual, downloadable at multilink.liebert.com
- Contact Closure (ML9P9S) Cable
- USB Cable
- Tower Stand
- Mounting Hardware
- Rack-Mount Handles
- Fixed Mounting Rails
- EPO Connector
- Input Power Cord, 2200/3000 only: 2
- IEC Output Cable, 750/1000/1500 only: 2
- IEC Output Cable, 2200/3000 only: 3
- (1) Schuko to IEC-320-C19 and (1) UK plug to IEC-320-C19 input cord, 2200/3000 only
- (2) IEC-320-C13, 750/1000/1500 only
- (3) IEC-320-C13, 2200/3000 only

Figure 4 Accessories

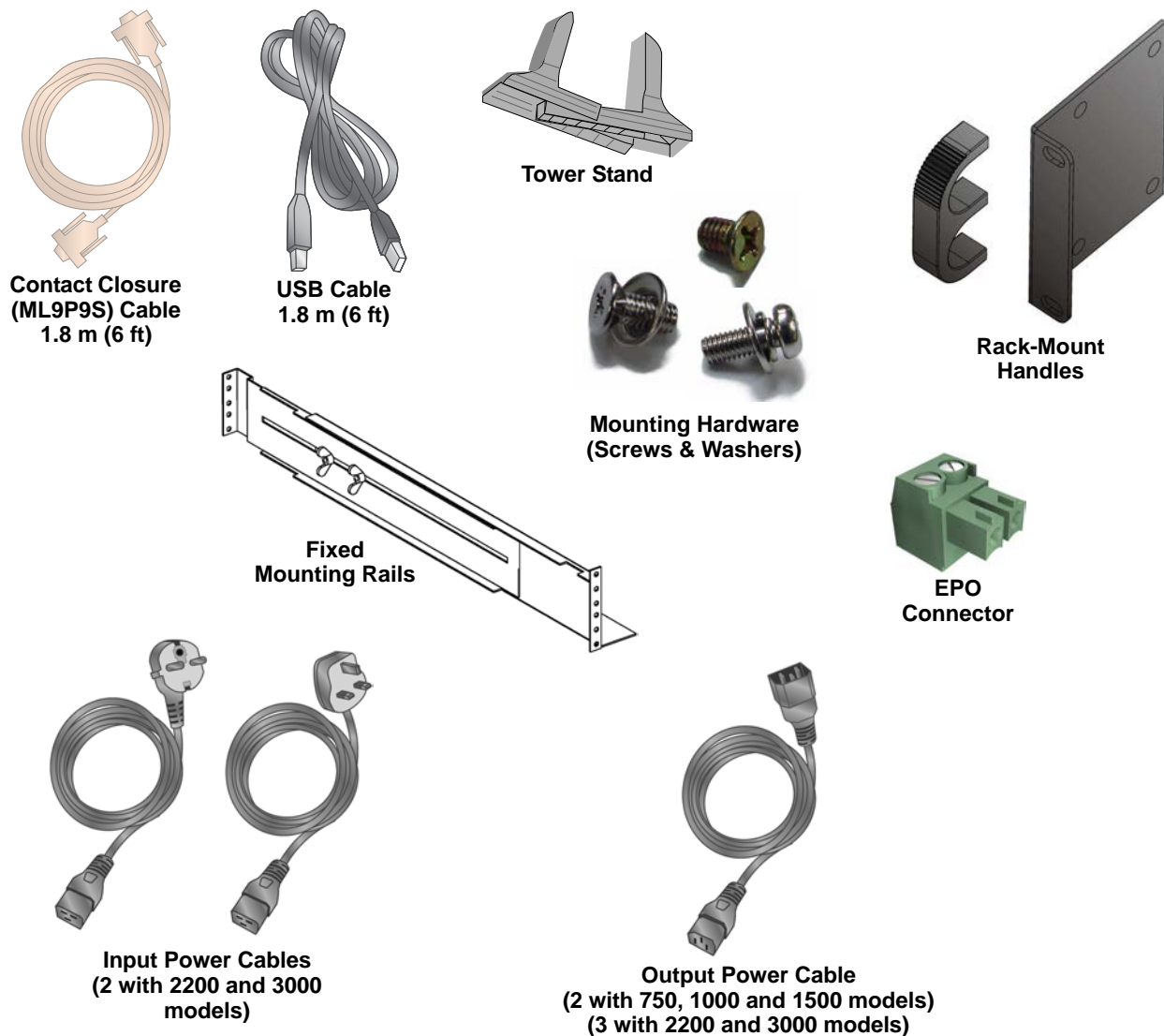

3.0 INSTALLATION

3.1 Preparation

Inspect the UPS for freight damage. Report any damage to the carrier and your local dealer or Emerson representative.



CAUTION

Risk of injury from heavy unit. May cause equipment damage or personal injury.

The UPS is heavy (see **Table 5**). Take proper precautions when lifting or moving the UPS.

The Liebert PSI may be installed in either a tower or rack configuration. Determine the method that suits the application and proceed.

Decide where to install the Liebert PSI. The UPS must be installed indoors in a controlled environment. Place it in an area with unrestricted airflow around the unit, away from water, flammable liquids, gases, corrosives and conductive contaminants (see **Figure 5**).

Maintain a minimum clearance of 305mm (12 inches) in the front and rear of the UPS. Maintain an ambient temperature range of 0°C to 40°C (32°F to 104°F) (see **Figure 5**).

Figure 5 Placing the Liebert PSI

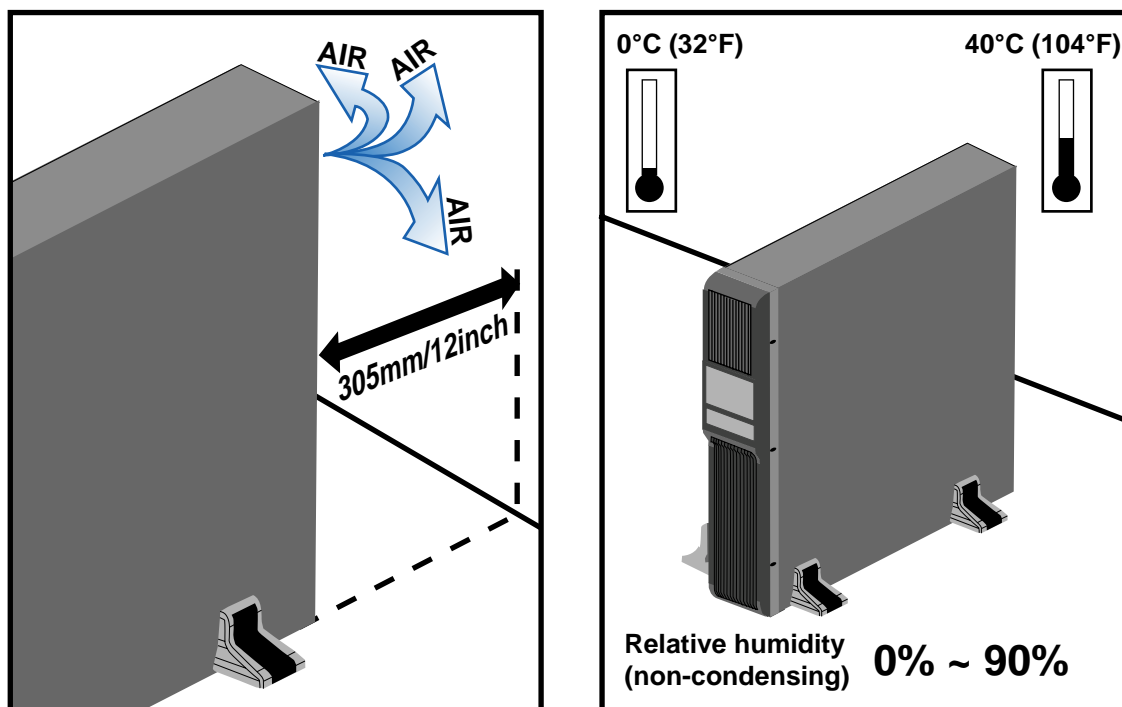

3.2 Tower UPS Installation

See **Figure 6** when using the Liebert PSI in a tower configuration.

Figure 6 Tower configuration—attach Tower Stand

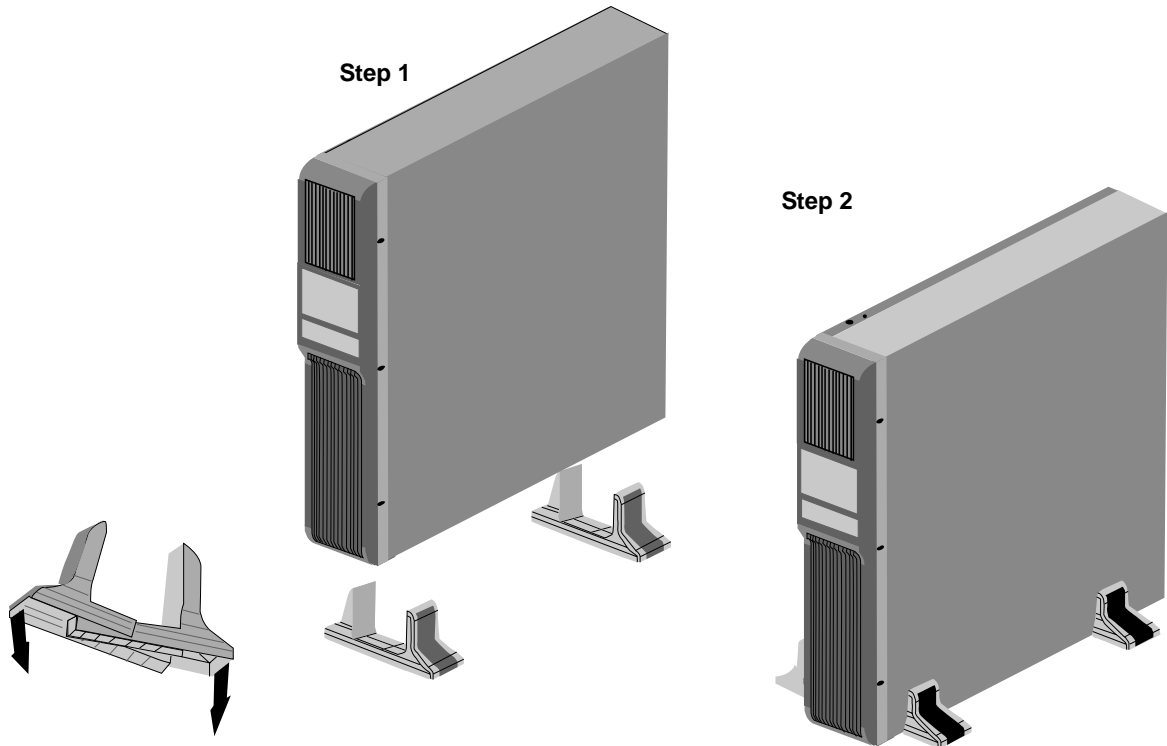

3.3 Rack-Mount UPS Conversion and Installation

See **Figure 7** when installing the Liebert PSI in a rack.

Figure 7 Convert the Liebert PSI for rack installation

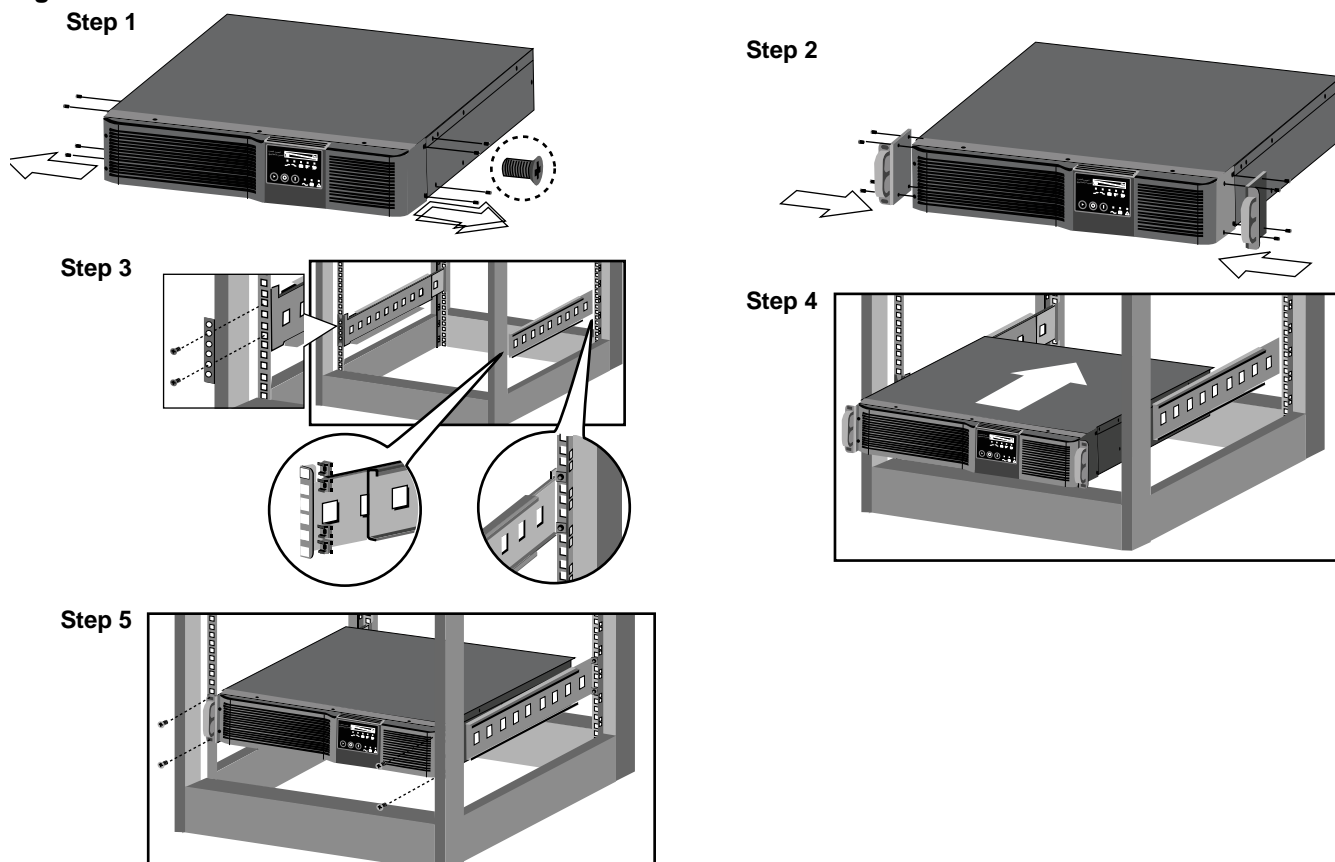

WARNING

Risk of top-heavy unit falling over. May cause equipment damage, personal injury or death.

Placing heavy equipment near the top of a rack may increase the risk of tipping. Place the UPS in the bottom of the rack.



CAUTION

Risk of strain from lifting heavy equipment. May cause personal injury.

Lifting equipment into rack may be a two-person job, depending on weight of equipment.

NOTICE

When rack-mounted, the UPS must be supported by a shelf, slide rails, brackets or fixed rails on each side. The rack-mount handles **WILL NOT** support the weight of the UPS. They are used to move the UPS into and out of the rack.

3.4 Orient Display for Installation

The Liebert PSI features a rotating display that may be oriented for either tower or rack installations. To set the display for your installation, pull out on the display and rotate it until it is oriented correctly, then press it into the UPS until it is seated.

Figure 8 Orienting the UPS display



3.5 Connect Input Power and Load

The 750, 1000 and 1500 models do not include an input power cable; use input power cord from computer equipment as input power cord of UPS. The 2200 and 3000 UPSs include an input power cable.

Connect input power to the UPS, then plug the equipment into the sockets on the rear of the UPS. These UPS sockets provide battery backup and surge protection to the equipment when mains power fails, spikes or sags (see **Figure 9**).

Figure 9 Connect mains power and load

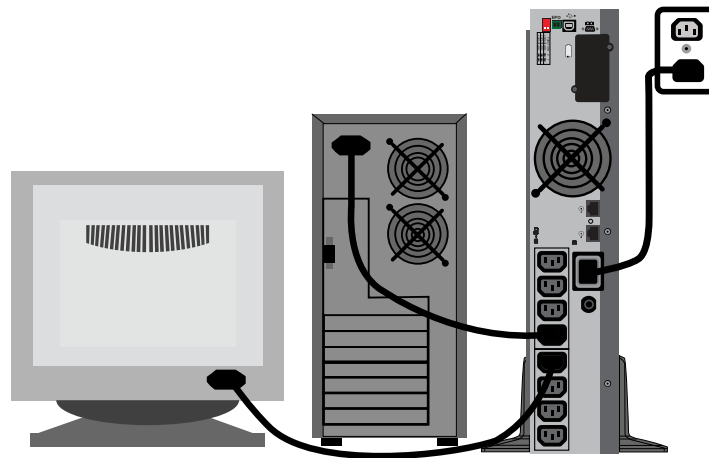

3.6 Connect Network Surge protection

Connect a 10 base-T/100 network cable to the RJ-45 network surge protection IN jack on the rear of the UPS. Connect from the OUT jack with network cabling to network equipment (see **Figure 10**).

Figure 10 Connect network surge protection

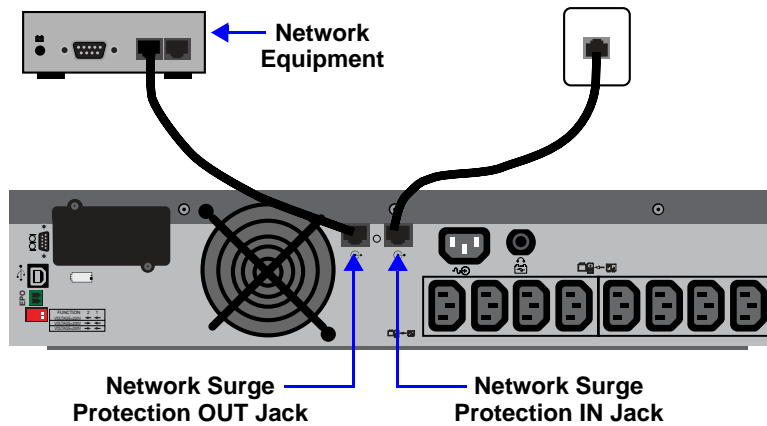

3.7 Connect Communication Interface

Determine what type of communication connection to use to manage the UPS. The Liebert PSI can be monitored with any of these communication methods:

- Contact closure
- USB
- SNMP (requires optional IS-WEBRT3 card)

See **3.8 - Set Up Liebert MultiLink software** for details and installation information. Also refer to **6.4 - UPS Communications**.

Figure 11 Connect communication interface

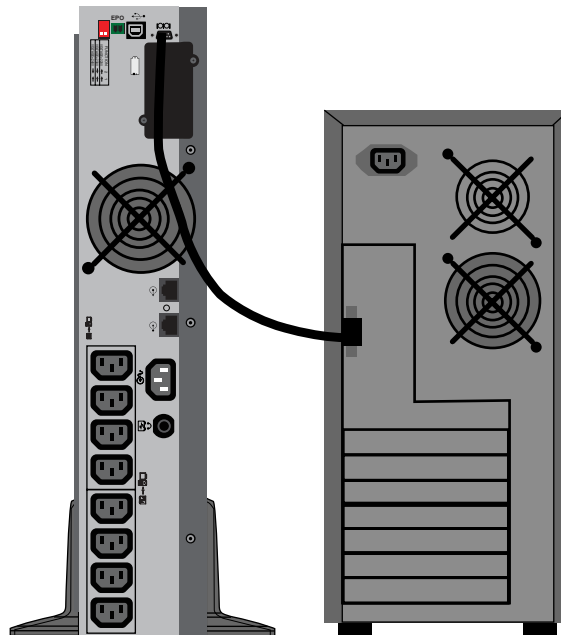

3.8 Set Up Liebert MultiLink software

To start using Liebert MultiLink (software and user manual available at multilink.liebert.com):

- Install the software.
See the Liebert MultiLink quick-start guide or user manual for installation instructions.
- Connect one end of the USB cable (supplied) to the USB port on the rear of the UPS. Connect the other end to a USB port on the computer.
See the Liebert MultiLink user manual for operating instructions.



NOTE

*Emerson recommends connecting the USB cable directly to the computer **WITHOUT** using a USB hub.*

3.9 EPO Switch

The Liebert PSI is equipped with an Emergency Power Off (EPO) switch. The user must supply a means of interfacing with the EPO circuit to allow disconnecting the UPS input feeder breaker to interrupt all sources of power to the UPS and connected equipment to comply with national and local wiring codes and regulations.

Figure 12 EPO connection for normally open operation

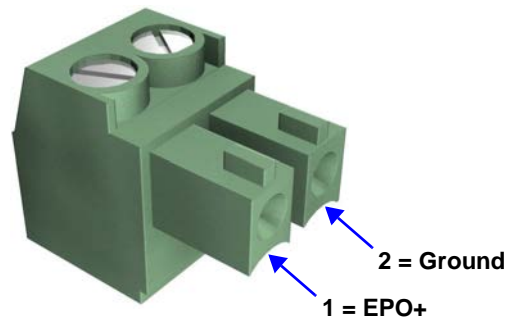

Short Pin 1 and Pin 2 to enable the EPO function

4.0 CONTROLS AND INDICATORS

Buttons on the front panel display control the Liebert PSI. Eight LEDs on the panel indicate the UPS's status. Refer to **Figure 13** and **Table 1**.

Figure 13 Display and status indicators

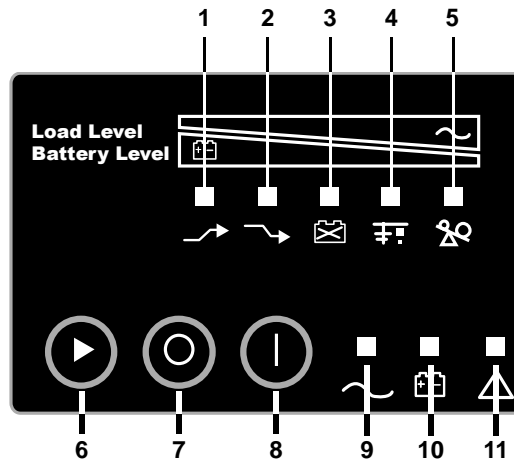

Table 1 Display and status indicators function, legend

Item	Name	Status Indicators	Description
1	LED 1	AVR Boost	UPS Operation in AVR Boost Mode
2	LED 2	AVR Buck	UPS Operation in AVR Buck Mode
3	LED 3	Battery Condition	Battery Fault/Weak
4	LED 4	Load Indicator/Battery run time*	Indicates load and battery run time
5	LED 5	Overload	UPS Overload
1 to 5	Load/Battery Level		Indicate Load/Battery Level
6	Status Change Button		Switches Display from Load Level Indicators to Battery Level Indicators
7	OFF Button		UPS Off
8	ON Button		Turn on UPS, Manual Self-Diagnostic (Normal Mode), Silence Alarm (Battery Mode)
9	LED 9	Normal Mode	UPS Operation in Normal Mode
10	LED 10	Battery Mode	UPS Operation in Battery Mode
11	LED 11	UPS Fault	UPS Fault

* Site wiring fault LED is used only to indicate load and battery run time with 230V units

4.1 Control Buttons



4.1.1 On/Alarm Silence/Manual Self-Diagnostic Test

This button controls output power to connected load(s). It has three functions:

- On
- Alarm Silence
- Manual Self-Diagnostic Test

ON—Start the UPS by pressing this button for more than 3 seconds, then releasing the button (an alarm will sound briefly). If the ON button is pressed and mains is outside input parameters, the UPS will start on battery (dark start).

Alarm Silence—Silence a Battery Mode audible alarm by pressing this button for longer than one second, then releasing it.

Manual Self-Diagnostic Test—To initiate a Manual Self-Diagnostic, press this button for at least three (3) seconds while operating from the mains. UPS will switch to Battery Mode to detect battery voltage and whether the UPS is operating normally.

If LED indicates the battery is weak: Allow the UPS to recharge the batteries for 8 hours. Retest the battery after recharge.

If LED still indicates the battery is weak after the battery has been retested, contact your local dealer, local Emerson representative or Channel Support Applications.

If LED indicates a Battery Fault: Contact your local dealer, local Emerson representative or Channel Support Applications.

If LED indicates a UPS Fault: Remove the load, retest the self-diagnostic test, if LED indicated UPS Fault, Contact your local dealer, local Emerson representative or Channel Support Applications.



NOTE

Refer to **Figure 13** and **Table 1** for details about the LEDs' meaning.



4.1.2 Off Button

When the UPS is operating in either Normal Mode or Battery Mode, pressing the Off button for more than three seconds will shut down the UPS.

4.2 Status Indicators



4.2.1 Status Change Button

The Status Change button determines the information displayed by the five LEDs on the front panel. The default information shown by the LEDs is the load level on the UPS. Pressing the Status Change button while the UPS is On prompts the LED display to show battery capacity for 5 seconds. This function assists in assessing the meaning of status indicators as described in **4.2.4 - UPS Status Indicators**. See **Figure 13** and **Table 1** for the Status Change button's location.

4.2.2 Load Level Indicator

The five LEDs at the top of the front panel illuminate with a steady glow to indicate the load level on the output of the UPS. The LEDs show the load level as a range, $\pm 5\%$. The LEDs' load level meanings and colors are:

LED 1	LED 2	LED 3	LED 4	LED 5
10-24% — Green	25-49% — Green	50-74% — Yellow	75-99% — Yellow	100% or greater — Red

4.2.3 Battery Level Indicator

The five LEDs illuminate with a steady glow to indicate battery capacity. Battery capacity is shown for five seconds after the Status Change button is pressed. The LEDs show the battery capacity as a range, $\pm 5\%$. The LEDs' battery level meanings and colors are:

LED 1	LED 2	LED 3	LED 4	LED 5
100-76% — Green	75-51% — Green	50-26% — Yellow	25-11% — Yellow	10% or less — Red

4.2.4 UPS Status Indicators

LEDs on the display panel illuminate with a steady glow or flash to indicate the UPS's status:

Mains Mode—The Mains Mode indicator illuminates (LED 9) with a steady glow when mains power is available and within the input specifications.

Battery Mode—The Battery Indicator illuminates (LED 10) with a steady glow when the UPS is operating on battery.

AVR Boost, AVR Buck—When the UPS is in AVR Boost/Buck Mode, the LED display will indicate the relative load level on the output of the UPS and will flash LED 1 (boost) or LED 2 (buck) to indicate which mode the UPS is in.

Weak Battery—When the UPS battery voltage is low, the LED display will indicate the relative load level on the output of the UPS and LED 3 will flash as a warning.

Overload—When UPS operates in overload status, the LED display will indicate the relative load level on the output of the UPS and LED 5 will flash as a warning.

Table 2 Status indicators—color, illumination mode

Status	LED 1	LED 2	LED 3	LED 4	LED 5	LED 9	LED 10	LED 11
Normal Mode						Green Steady		
AVR Boost	Green Flashes					Green Steady		
AVR Buck		Green Flashes				Green Steady		
Battery Mode (dark start)							Yellow Steady	
Weak Battery			Yellow Flashes					
Site-Wiring Fault				<i>Not applicable</i>				
Overload					Red Flashes			
Battery Fault Shutdown			Yellow Steady					Red Steady
Overload Shutdown					Red Steady			Red Steady
UPS Output Abnormal Shutdown							Yellow Steady	Red Steady

5.0 OPERATIONAL MODES

5.1 Normal Mode

When the UPS is in Normal Mode, the Normal Mode Indicator illuminates green.

5.2 Buck/Boost Mode

The Automatic Voltage Regulator (AVR) circuitry compensates for fluctuations in mains power, such as voltage surges and sags. The Liebert PSI compensates for these by raising the undervoltage (boost) or lowering the overvoltage (buck). The AVR operates automatically and maintains the output voltage to the connected equipment without utilizing the batteries.

5.3 Battery Mode

The UPS switches to Battery Mode in the event of an extreme input voltage/frequency condition or mains failure.

When the UPS is in Battery Mode, the Battery Indicator illuminates amber and an alarm sounds at 2-second intervals. As capacity decreases, fewer indicators remain illuminated.

When a Low Battery condition occurs, the Battery Indicator flashes amber and an alarm sounds at one-second intervals. For approximate battery run times, refer to **Table 6**.

5.4 Battery Recharge Operation

Once mains power is restored, the UPS resumes normal operation, and the Battery Charger begins recharging the batteries.

6.0 COMMUNICATION

6.1 DB-9 Connector

The UPS has a DB-9 (9 pin female) connector on the rear to allow UPS status communications with a computer running Liebert MultiLink software in contact closure mode. The connection provides On Battery and Low Battery notification.

When power is interrupted and battery power is low, Liebert MultiLink software can signal the host computer to gracefully shut down the operating system.

Table 3 DB-9 pin assignment

DB-9 Pin	Assignment Description
1	Low Battery (open collector)
2	UPS TxD (not used)
3	UPS RxD (not used)
4	Remote Shutdown (5-12V); on-battery operation
5	Common
6	Output Off, (short to Pin 5, non-latching); any mode operation
7	Low Battery (open emitter)
8	Mains Fail (open emitter)
9	Mains Fail (open collector)

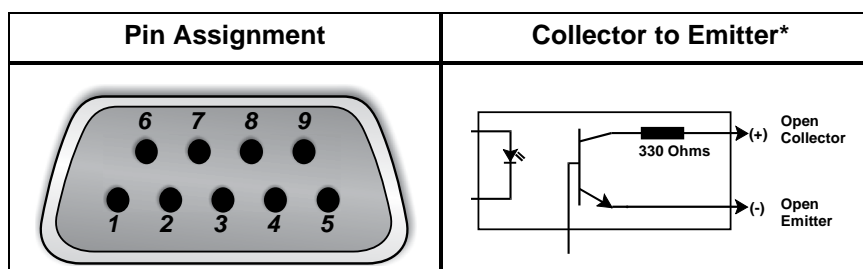

6.2 Remote Shutdown Via the DB-9 Connector

The Liebert PSI can be shut down remotely by shorting Pins 5 and 6 or via Pins 4 and 5 of the DB-9 connector.

6.2.1 Any Mode Shutdown Via Pins 5 & 6

When Pin 6 is shorted to Pin 5, the UPS output is shut Off no matter what mode the UPS is operating. The UPS cannot be started as long as the pins are shorted. When the short is removed, the UPS output can be enabled by pressing the ON/Alarm Silence/Manual Self-Diagnostic Test button.

6.2.2 Battery Mode Shutdown Via Pins 4 & 5

While the UPS is operating on battery, a 5-12VDC signal for 2 seconds or longer is required to signal a shutdown. Signals for less than 2 seconds are ignored.

After Pin 4 receives the shutdown signal, a 2-minute shutdown timer begins a countdown. The shutdown timer cannot be stopped: If mains power returns during the 2-minute countdown, the shutdown timer continues until the end of 2 minutes and the UPS turns Off. The UPS will restart 10 seconds after mains power returns.

6.3 RJ-45 Data Line Protection Connectors

Data line (in and out) connectors on the rear of the UPS provide transient voltage surge suppression (TVSS) for network devices.

6.4 UPS Communications

The Liebert PSI is equipped with a Liebert IntelliSlot port to provide advanced communication and monitoring options.

Liebert MultiLink software continually monitors the UPS and can shut down your computer or server via USB, contact closure and SNMP (via IS-WEBRT3 card) in the event of an extended power failure.

The Liebert IS-WEBRT3 provides SNMP and Web-based monitoring and control of the UPS across the network.



NOTE

The USB, SNMP and contact closure communications can operate in parallel.

6.5 UPS Inverter/Transfer Voltage Configurations

A two-pin DIP switch on the rear of the Liebert PSI permits setting the UPS to operate at nominal voltages of 220V, 230V or 240V. This feature will change the high and low points at which the UPS switches to battery power. It also will change the UPS' output voltage when the UPS is operating in battery mode. The factory default setting is 230 VAC.

Turn Off the UPS before making these changes to the voltage configuration.

Figure 14 DIP switch settings for 230V system

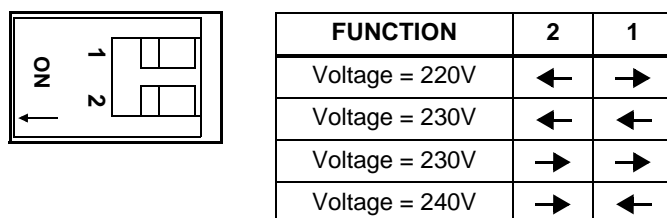

Table 4 Voltage configurations

Setting	Input Voltage Range	Output Voltage (Battery Mode)
220	165~275	220VAC
230	173~288	230VAC
240	180~300	240VAC

7.0 BATTERY MAINTENANCE

7.1 Battery Charging, Storage

The batteries are valve-regulated, nonspillable, lead acid and must be kept charged to retain their design life. The Liebert PSI continuously charges the batteries when connected to the mains supply, even while the UPS is switched Off.

If the Liebert PSI will be stored for an extended period, Emerson recommends connecting the UPS to input power for at least 8 hours every four to six months to keep the batteries charged.

7.2 Internal Battery Replacement Procedure

NOTICE

This UPS is equipped with internal batteries that the user can replace without shutting down the UPS or connected loads (hot swappable). Caution must be exercised when replacing the batteries because the load is unprotected from power fluctuations and power failures.

To replace the batteries:

1. Remove the two screws on the left side of the front bezel.
2. Pull the front bezel off the UPS.
3. Remove the screw on the battery connector holder.
4. Remove the two screws on the battery bracket.
5. Disconnect the two slotted, red/gray and black battery connectors.
6. Grasp the battery pack assembly by the handle and pull it out of the front of the UPS.
7. Unpack the new battery assembly, taking care not to destroy the packing.
8. Compare the new and old battery assemblies to make sure they are the same. If so, proceed with replacement. If they are different, STOP and contact your local dealer, local Emerson representative or Channel Support Applications.
9. Slide the new battery pack into the UPS.
10. Reattach the battery bracket with the two screws.
11. Reconnect the slotted, red/gray and black battery connectors.
12. Reinsert the screw on the battery connector holder.
13. Reattach the front bezel.

Figure 15 Battery replacement

Step 1



Step 2



Step 3

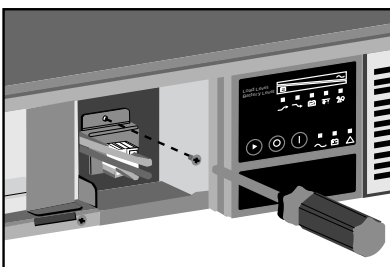

Step 4

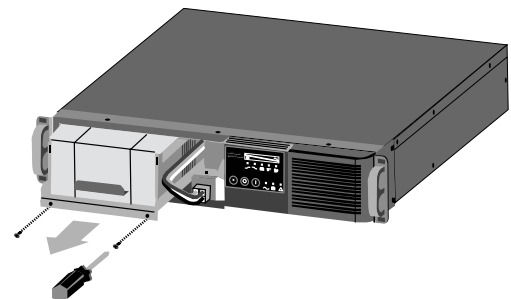

8.0 SPECIFICATIONS

Table 5 Liebert PSI specifications

Model Number	PS750RT3-230	PS1000RT3-230	PS1500RT3-230	PS2200RT3-230	PS3000RT3-230
Power Rating	750VA/675W	1000VA/900W	1500VA/1350W	2200VA/1980W	3000VA/2700W
Dimensions, W x D x H, in (mm)					
Unit	440 x 412 x 88 (17.3 x 16.2 x 3.5)			440 x 657 x 88 (17.3 x 25.9 x 3.5)	
Shipping	560 x 595 x 228 (22 x 23.4 x 9)			560 x 776 x 228 (22 x 30.6 x 9)	
Weight, kg (lb)					
Unit	15 (33.1)	19.4 (42.8)	20.9 (46.1)	33.8 (74.5)	37.2 (82)
Shipping	18.2 (40.1)	22.6 (49.8)	24.1 (53.1)	38.3 (84.4)	41.5 (91.5)
Input AC Parameters					
Surge Protection	220J				
Voltage Range Without Battery Operation	165~300, Configurable				
Frequency Range	45~65Hz, (±0.5Hz)				
Input Socket	IEC-320-C14			IEC-320-C20	
Output Receptacles	(8) IEC-320-C13			(8) IEC-320-C13 (1) IEC-320-C19	
Voltage, Normal Mode	220/230/240 VAC, Configurable, ±10%				
Voltage, Battery Mode	220/230/240 VAC , Configurable; ±5% Before Low Battery Warning				
Transfer Time	4-6 ms, Typical				
Waveform	Sinewave				
Frequency, Battery Mode	50/60Hz, (±0.5Hz), Autosensing				
Overload Warning					
Normal Mode	>100% - 109%		Continuous Overload Alarm and Power to the Load		
	>110% - 120%		Shut down after 10 minutes		
	>120%		Shut down UPS immediately		
Battery Mode	>100% - 119%		Continuous Overload Alarm Till End of Battery Discharged		
	>120% - 130%		Shut down after 10 seconds		
	>130%		Shut down UPS immediately		
Battery Parameters					
Type	Valve-Regulated, Nonspillable, Lead Acid				
Quantity x Voltage x Ah	2 x 12 x 7.2	3 x 12 x 7.2	3 x 12 x 9	6 x 12 x 7.2	6 x 12 x 9
Backup Time	See Table 6				
Recharge Time	5 hours to 90% of rated capacity, after full discharge into resistive load				

Table 5 Liebert PSI specifications (continued)

Model Number	PS750RT3-230	PS1000RT3-230	PS1500RT3-230	PS2200RT3-230	PS3000RT3-230
Power Rating	750VA/675W	1000VA/900W	1500VA/1350W	2200VA/1980W	3000VA/2700W
Environmental					
Operating Temperature	0°C to 40°C (32°F to 104°F)				
Storage Temperature	-15°C to 40°C (5°F to 104°F)				
Relative Humidity	0% to 90%, non-condensing				
Operating Altitude	Up to 3000m (10,000 ft.) at 35°C (95°F) without derating				
Audible Noise	<45 dBA				
Agency					
Safety	IEC/EN/AS 62040-1-1				
Surge	IEC/EN/AS61000-4-2				
ESD	IEC/EN/AS61000-4-3				
Susceptibility	IEC/EN/AS61000-4-4				
Electrical Fast Transient	IEC/EN/AS 62040-2 2nd Ed class A				
Emissions	IEC/EN/AS61000-4-6				
Conducted Immunity	IEC/EN/AS61000-3-2				
Harmonics	IEC/EN/AS61000-4-6				
Transportation	ISTA Procedure 1A Certification				
Environmental	ROHS compliant 				

Table 6 Load Autonomy - Liebert PSI 750VA-3000VA

	Load %	750VA	1000VA	1500VA	2200VA	3000VA
Internal Battery	10	84	93	76	82	76
	20	45	47	32	44	32
	30	25	26	17	19	17
	40	15	15	12	14	12
	50	11	12	9	11	9
	60	9	9	7	9	7
	70	7	7	5	7	5
	80	5	6	4	5	4
	90	4	5	3	4	3
	100	4	4	3	3	3

Note: All run times are in minutes, assume fully charged batteries and are typical at 25°C (77°F) with resistive loads.

9.0 TROUBLESHOOTING

The information below indicates various symptoms a user may encounter in the event the Liebert PSI experiences a problem. See **Table 7** for suggested solutions.

1. An alarm sounds, alerting that the UPS requires attention. The alarm can be silenced except for low battery, overload warning and fault.
2. One or more additional indicators will be illuminated to provide a diagnostic aid to the operator, as described below:

If the UPS fails to operate properly, turn Off the unit and repeat the steps in **3.0 - Installation**. If the problem persists, refer to **Table 7**.

Table 7 Troubleshooting—problems, causes and solutions

Problem	Cause	Solution
UPS will not start	Short circuit	Check the circuit breaker on the rear of the UPS. If it is tripped, reset it and restart the UPS. For help, contact your local dealer, local Emerson representative or Channel Support Applications.
	Battery is disconnected or completely discharged	Check for proper connection of battery or batteries.
UPS starts on battery, but will not switch to AC (dark start)	UPS not plugged in	Plug in the power cord securely.
	Circuit breaker tripped	Reset the circuit breaker and restart the UPS.
	AC overvoltage	Wait until voltage drops to an appropriate level or have the utility power checked by a properly trained and qualified electrician.
UPS shuts down	Short circuit or UPS output is abnormal; LED 10 and LED 11 illuminate and sound audible alarm	Remove the load and turn on the UPS again. For help, contact your local dealer, local Emerson representative or Channel Support Applications.
	Overload; LED 5 and LED 11 illuminate and sound audible alarm	Check load level display and remove nonessential loads. Recalculate the load and reduce equipment connected to UPS - the total wattage must not exceed the capacity of the UPS.
	LED 3 and LED 11 illuminate and sound audible alarm	Recharge the battery for 8 hours, then turn ON the UPS.
	Liebert MultiLink software	Consult the Liebert MultiLink user manual or contact your LAN administrator.
Battery weak LED (LED 3) flashing	Batteries weak	Recharge batteries.
	Batteries need to be replaced	Replace batteries.

Ensuring The High Availability Of Mission-Critical Data And Applications.

Emerson Network Power, the global leader in enabling business-critical continuity, ensures network resiliency and adaptability through a family of technologies—including Liebert power and cooling technologies—that protect and support business-critical systems. Liebert solutions employ an adaptive architecture that responds to changes in criticality, density and capacity. Enterprises benefit from greater IT system availability, operational flexibility and reduced capital equipment and operating costs.

While every precaution has been taken to ensure the accuracy and completeness of this literature, Liebert Corporation assumes no responsibility and disclaims all liability for damages resulting from use of this information or for any errors or omissions.

© 2009 Liebert Corporation

All rights reserved throughout the world. Specifications subject to change without notice.

® Liebert is a registered trademark of Liebert Corporation.

All names referred to are trademarks or registered trademarks of their respective owners.

SLI-23319_REV0_04-09

Emerson Network Power.

The global leader in enabling *Business-Critical Continuity*.

- AC Power
- Embedded Computing
- Outside Plant
- Racks & Integrated Cabinets
- Connectivity
- Embedded Power
- Power Switching & Controls
- Services
- DC Power
- Monitoring
- Precision Cooling
- Surge Protection

Business-Critical Continuity, Emerson Network Power and the Emerson Network Power logo are trademarks and service marks of Emerson Electric Co.

©2009 Emerson Electric Co.