

ACUMAX® sealed maintenance-free lead-acid battery AFT series



AFT 125-12

Sealed, maintenance free, lead-acid **ACUMAX®** batteries with a **10 - 12** years designed lifetime are made in **AGM** technology - electrolyte is absorbed in highly porous fiber glass separators placed between the plates. They use a gas recombination cycle which prevents electrolyte loss and allows the batteries to be used in rooms without forced ventilation, that are occupied by people. One-way, self-regulating pressure relief valves prevent the case from blowing up, by preventing excessive buildup of pressure in the cells.

- uninterruptible power supplies
- telecom power supply systems
- telecommunication PABX
- power station
- fire and security systems
- solar powered systems
- emergency lighting systems
- cable TV

Main applications

- marine
- golf-carts, wheelchairs
- mobile and portable equipment
- medical equipment

Technical data

Nominal voltage	12 V
Nominal capacity	125 Ah/ C ₁₀
Design life	8 years @ 25°C 10-12 years @ 20°C according to Eurobat, High Performance group
Weight	~ 41.5 kg
Dimensions	
Height	287 mm
Length	551 mm
Width	110 mm
Internal resistance	≤ 3.2 mΩ
Charging voltage @ 25°C	
Standby use	13.65 V ± 0.15 V
Cycle use	14.70 V ± 0.30 V
Charging current	
Recommended	12.0 A
Maximum	37.5 A
Max. discharge current (5s)	1100 A
Container material	
Standard	ABS UL 94-HB
Optional (Flame-retardant)	ABS UL 94-V0

Battery approved for transportation by air, sea or land. Classified as non-hazardous material: *IATA/ICAO Special Provision A67, DOT-CFR Title 49 parts 171-189, IMDG amendment 27.*

Discharge characteristics

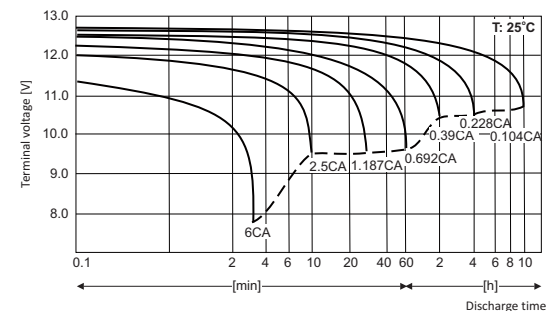

Dimensions

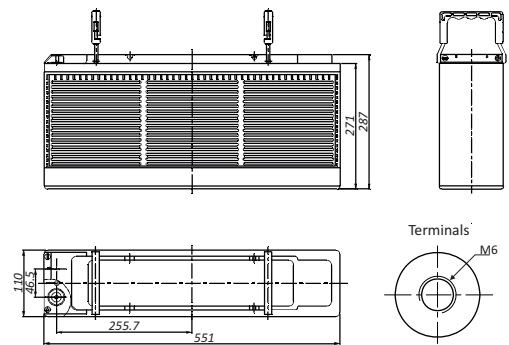

Constant current discharge (Current [A], 25 [°C] / 77 [°F])

U _f [V/cell]	Discharge time													
	10 min	15 min	20min	30 min	45 min	1h	2h	3h	4h	5h	6h	8h	10h	20h
1,80	210,0	183,5	159,0	123,8	93,8	75,5	43,9	32,2	25,6	21,5	18,5	14,9	12,5	6,62
1,75	231,8	197,5	169,5	129,0	96,5	77,5	44,9	32,7	26,0	21,7	18,8	15,1	12,6	6,68
1,70	246,8	207,0	176,3	133,8	99,0	78,8	45,6	33,1	26,3	22,0	19,1	15,3	12,8	6,73

Constant power discharge (Power [W/cell], 25 [°C] / 77 [°F])

U _f [V/cell]	Discharge time													
	10 min	15 min	20min	30 min	45 min	1h	2h	3h	4h	5h	6h	8h	10h	20h
1,75	420,9	363,1	315,2	242,7	184,2	149,6	87,3	63,7	50,9	42,7	37,1	29,9	25,2	13,33
1,70	438,1	375,3	325,3	250,2	188,3	151,5	88,3	64,5	51,5	43,0	37,5	30,3	25,4	13,42
1,67	456,3	386,4	330,9	254,8	191,2	153,3	89,4	64,9	51,9	43,5	37,8	30,5	25,6	13,46

U_f - Final voltage

