

NPL-Series - Valve Regulated Lead Acid Battery

NPL200-6 (FR)

Data Sheet

SPECIFICATIONS		
Nominal voltage	6	V
20-hr rate Capacity to 10.5V at 20°C	200	Ah
10-hr rate Capacity to 10.8V at 20°C	176	Ah
DIMENSIONS		
Length	398 (±0.7)	mm
Width	176 (±0.5)	mm
Height	250 (±0.7)	mm
(height over terminals)	N/A	mm
Mass (typical)	39.0	kg
TERMINAL TYPE		
Post type terminal	10	mm
Torque	16.5	Nm
OPERATING TEMPERATURE RANGE		
Storage (in fully charged condition)	-20°C to +50°C	
Charge	-15°C to +50°C	
Discharge	-20°C to +60°C	
STORAGE		
Capacity loss per month at 20°C (approx)	3	%
CASE MATERIAL		
Standard Option	ABS (UL 94:HB)	
Flame retardant option (FR)	ABS (UL94:V0)	
CHARGE VOLTAGE		
Float charge voltage at 20°C	6.825 (±1%)	V
	2.275 (±1%)	V/cell
Float Charge voltage temperature correction factor (for variations from the standard 20°C)	-3	mV/cell/°C
Cyclic (or Boost) charge at 20°C	7.26 (±3%)	V
	2.42 (±3%)	V/cell
Cyclic Charge voltage temperature correction factor (for variations from the standard 20°C)	-4	mV/cell/°C
CHARGE CURRENT		
Float charge current limit	No limit	A
Cyclic (or Boost) charge current limit	50.00	A
MAXIMUM DISCHARGE CURRENT		
1 second	1500	A
1 minute	600	A
SHORT-CIRCUIT CURRENT & INTERNAL RESISTANCE (according to EN IEC 60896-21)		
Internal resistance	N/A	mΩ
Short-Circuit current	N/A	A
IMPEDANCE		
Measured at 1 kHz	1.3	mΩ
PERFORMANCE & CHARACTERISTICS		
Refer to the technical manual	NPL	
DESIGN LIFE		
EUROBAT Classification: High performance	10 to 12	years
Yuasa design life @ 20°C	up to 10	years
SAFETY		
Installation	Can be installed and operated in any orientation except permanently inverted	
Handles	Batteries must not be suspended by their handles (where fitted)	
Vent valves	Each cell is fitted with a low pressure release valve to allow gasses to escape and then reseal.	
Gas Release	VRLA Batteries release hydrogen gas which can form explosive mixtures in air. Do not place inside a sealed container	
Recycling	YUASA's VRLA batteries must be recycled at the end of life in accordance with local and national laws and regulations	

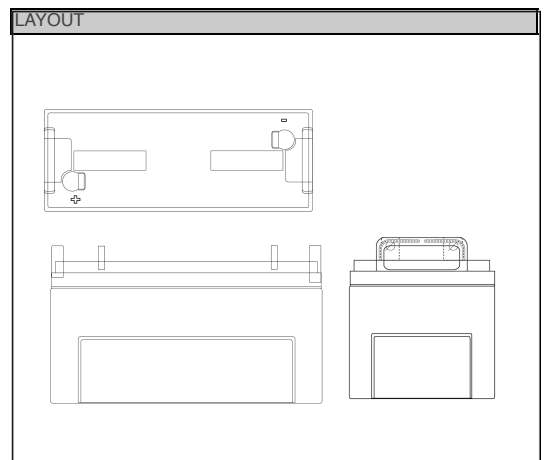

3RD PARTY CERTIFICATIONS

ISO 9001 - Quality Management Systems
 ISO 14001 - Environmental Management Systems
 EN 18001 - OHSAS Management Systems
 UNDERWRITERS LABORATORIES Inc.

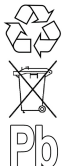

STANDARDS

IEC61056
 IEC60896-21/22



ALL DATA IS SUBJECT TO CHANGE WITHOUT NOTICE
 Issue No.: V.2 / Issue Date: March 2011

